

Алматы (7273)495-231
Ангарск (3955)60-70-56
Архангельск (8182)63-90-72
Астрахань (8512)99-46-04
Барнаул (3852)73-04-60
Белгород (4722)40-23-64
Благовещенск (4162)22-76-07
Брянск (4832)59-03-52
Владивосток (423)249-28-31
Владикавказ (8672)28-90-48
Владимир (4922)49-43-18
Волгоград (844)278-03-48
Вологда (8172)26-41-59
Воронеж (473)204-51-73
Екатеринбург (343)384-55-89

Иваново (4932)77-34-06
Ижевск (3412)26-03-58
Иркутск (395)279-98-46
Казань (843)206-01-48
Калининград (4012)72-03-81
Калуга (4842)92-23-67
Кемерово (3842)65-04-62
Киров (8332)68-02-04
Коломна (4966)23-41-49
Кострома (4942)77-07-48
Краснодар (861)203-40-90
Красноярск (391)204-63-61
Курск (4712)77-13-04
Курган (3522)50-90-47
Липецк (4742)52-20-81

Магнитогорск (3519)55-03-13
Москва (495)268-04-70
Мурманск (8152)59-64-93
Набережные Челны (8552)20-53-41
Нижний Новгород (831)429-08-12
Новокузнецк (3843)20-46-81
Ноябрьск (3496)41-32-12
Новосибирск (383)227-86-73
Омск (3812)21-46-40
Орел (4862)44-53-42
Оренбург (3532)37-68-04
Пенза (8412)22-31-16
Петрозаводск (8142)55-98-37
Псков (8112)59-10-37
Пермь (342)205-81-47

Ростов-на-Дону (863)308-18-15
Рязань (4912)46-61-64
Самара (846)206-03-16
Санкт-Петербург (812)309-46-40
Саратов (845)249-38-78
Севастополь (8692)22-31-93
Саранск (8342)22-96-24
Симферополь (3652)67-13-56
Смоленск (4812)29-41-54
Сочи (862)225-72-31
Ставрополь (8652)20-65-13
Сургут (3462)77-98-35
Сыктывкар (8212)25-95-17
Тамбов (4752)50-40-97
Тверь (4822)63-31-35

Тольятти (8482)63-91-07
Томск (3822)98-41-53
Тула (4872)33-79-87
Тюмень (3452)66-21-18
Ульяновск (8422)24-23-59
Улан-Удэ (3012)59-97-51
Уфа (347)229-48-12
Хабаровск (4212)92-98-04
Чебоксары (8352)28-53-07
Челябинск (351)202-03-61
Череповец (8202)49-02-64
Чита (3022)38-34-83
Якутск (4112)23-90-97
Ярославль (4852)69-52-93

Россия +7(495)268-04-70

Казахстан +7(7172)727-132

Киргизия +996(312)96-26-47

<https://odu.nt-rt.ru> || oud@nt-rt.ru

HIGH-SPEED DATA TECHNOLOGY CABLE ASSEMBLIES

HDMI   
ODU HIGH SPEED DATA TECHNOLOGY



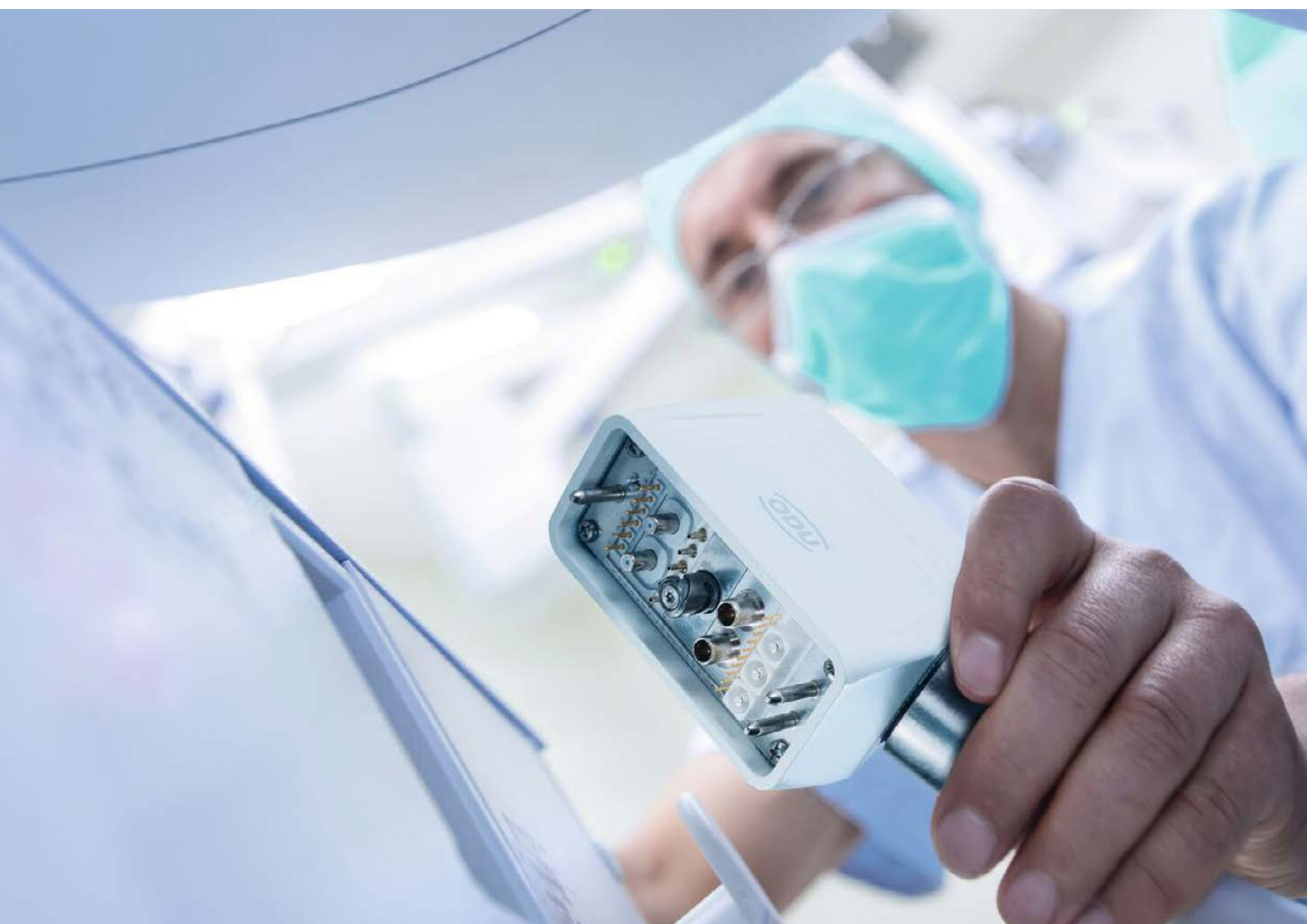

TABLE OF CONTENTS

| | |
|--|-----------|
| CONNECTOR AND CABLE OPTIONS | 5 |
| Cable number key | 5 |
| Cable specifications | 6 |
| Locking and style options | 12 |
| Coding and color options | 14 |
| ETHERNET/IP® | 16 |
| ODU AMC® | 18 |
| ODU AMC® High-Density | 19 |
| ODU AMC® Series T | 20 |
| ODU-MAC® Blue-Line | 21 |
| ODU MINI-SNAP® Series L | 22 |
| ODU MINI-SNAP® Series K | 24 |
| SPE | 26 |
| ODU MINI-SNAP® Series L | 28 |
| ODU MINI-SNAP® Series K | 30 |
| ODU-MAC® Blue-Line | 32 |
| DISPLAYPORT® | 34 |
| ODU AMC® | 36 |
| ODU AMC® Series T | 37 |
| ODU MINI-SNAP® Series L | 38 |
| ODU MINI-SNAP® Series K | 40 |
| ODU-MAC® Blue-Line | 42 |
| HDMI® | 44 |
| ODU AMC® | 46 |
| ODU AMC® Series T | 47 |
| ODU AMC® High-Density | 48 |
| ODU-MAC® Blue-Line | 49 |
| ODU MINI-SNAP® Series L | 50 |
| ODU MINI-SNAP® Series K | 52 |
| USB® | 54 |
| ODU AMC® | 56 |
| ODU AMC® High-Density | 57 |
| ODU MINI-SNAP® Series L | 58 |
| ODU MINI-SNAP® Series K | 62 |
| ODU-MAC® Blue-Line | 66 |

In the field of data technology, a standard cable assembly comprises usually an ODU connector at one end and a standard interface connector at the other end of the cable. You can also get a solution with ODU connectors on both sides of the cable assembly. The catalogue includes the following ODU connectors (availability depends on data protocol):

- ODU MINI-SNAP® (L/K)
- ODU AMC®
- ODU AMC® High-Density
- ODU AMC® Series T
- ODU-MAC® Blue-Line

Data transmission protocols

The contact arrangement of an ODU data transmission connector differs from a standard data transmission connector due to the robust ODU specific design. However, the ODU design meets the electrical specifications of the respective s





ODU FIBER OPTIC EXPANDED BEAM PERFORMANCE

Advanced fiber optic solution which offers high-end transmission characteristics over many mating cycles.

YOUR WAY TO AN INDIVIDUAL CABLE ASSEMBLY SOLUTION

HOW TO CONFIGURE WITH THE CABLE NUMBER KEY

This shows you how ODU's cable number key is composed:

- In the first part of the configuration – after the "C" for cable, please insert the first 6 positions of your connector number key.
- In the middle part of the cable number key, you configure bend relief, color and count number.
- The last 6 positions determine the length of the cable in mm.

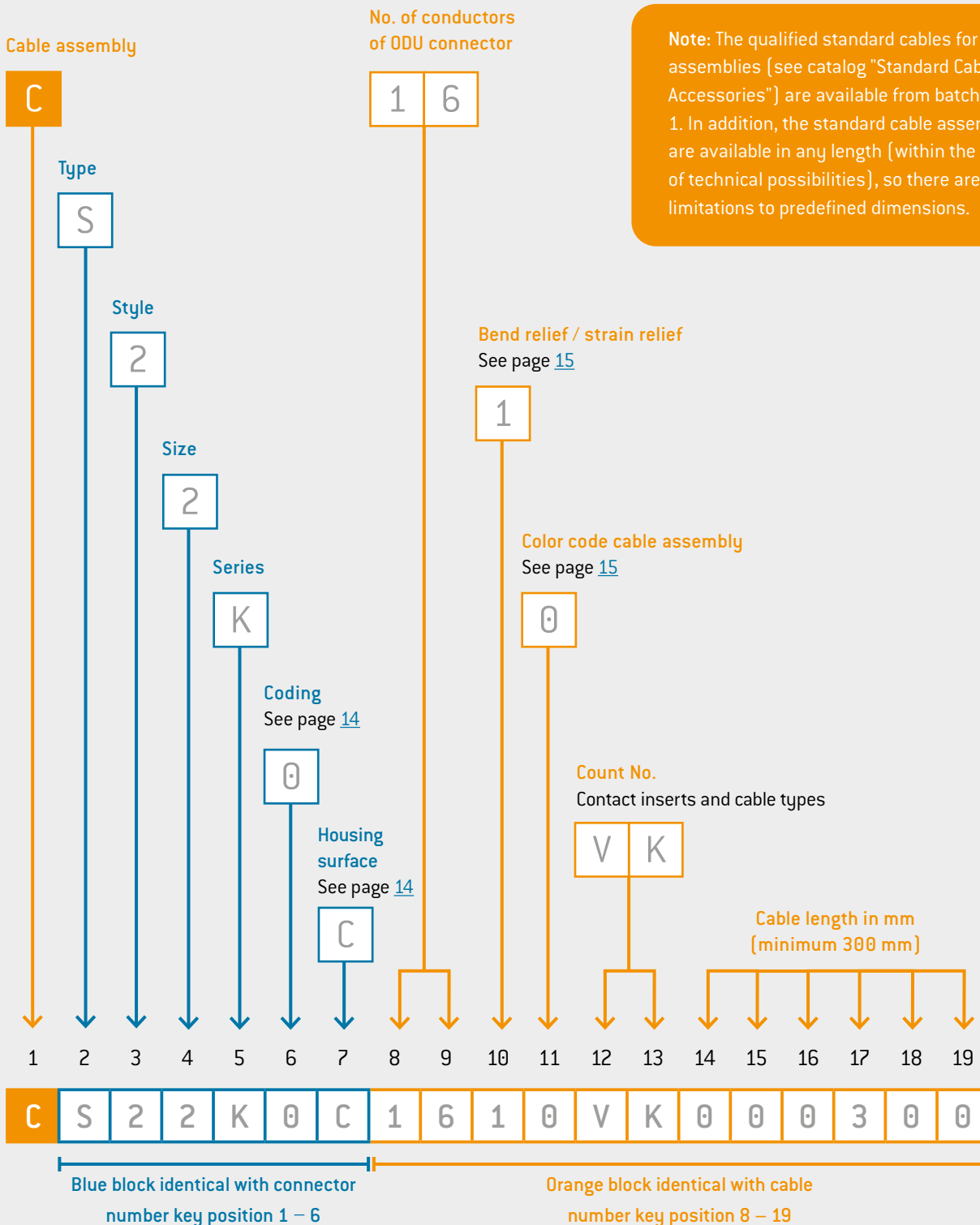

CABLE SPECIFICATIONS

TECHNICAL DATA

DATA CABLES SINGLE PAIR ETHERNET®

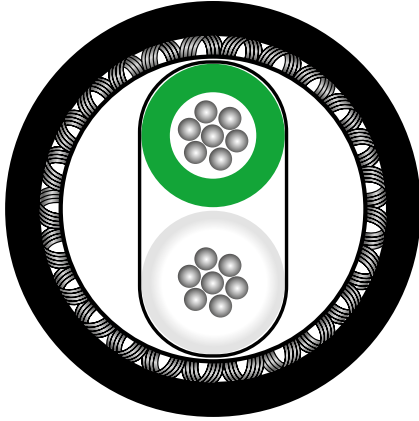

| TECHNICAL DATA | BY THE METER | PRE-ASSEMBLED |
|-------------------|-------------------------------------|------------------|
| Conductor | Tinned copper wire | |
| Composition | 1 x 2 x AWG 26 | 1 x 2 x AWG 22 |
| Stranding | 2 cores stranded to a pair | |
| Jacket / Color | PVC / Black ISO 19642-7, class B | PVC / Black |
| Insulation | PP Ø 1.26 mm | PE Ø 1.65 mm |
| Shielding | Tinned copper | |
| Temperature range | -40 up to +105 °C | -20 up to +80 °C |

DATA CABLES ETHERNET®

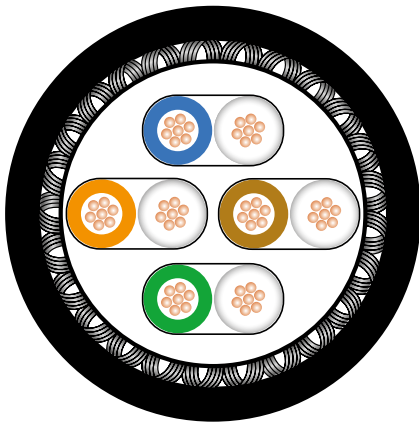

| TECHNICAL DATA | BY THE METER | PRE-ASSEMBLED |
|-----------------------|---|--|
| Conductor | Bare copper wire | |
| Stranding | 2 cores stranded to a pair – 4 pairs | |
| Insulation | Foam-Skin PE, 1.05 mm | PE Ø 1.02 mm (core) |
| Jacket / Color | DMC FLEX PUR, Black | LSZH (jacket) / PVC (bend relief) / Black |
| Shielding | Tinned copper braid | |
| Pair shielding | Aluminium-coated plastic composite foil | |
| Operating temperature | -20 °C to +60 °C | -40 °C to +75 °C |

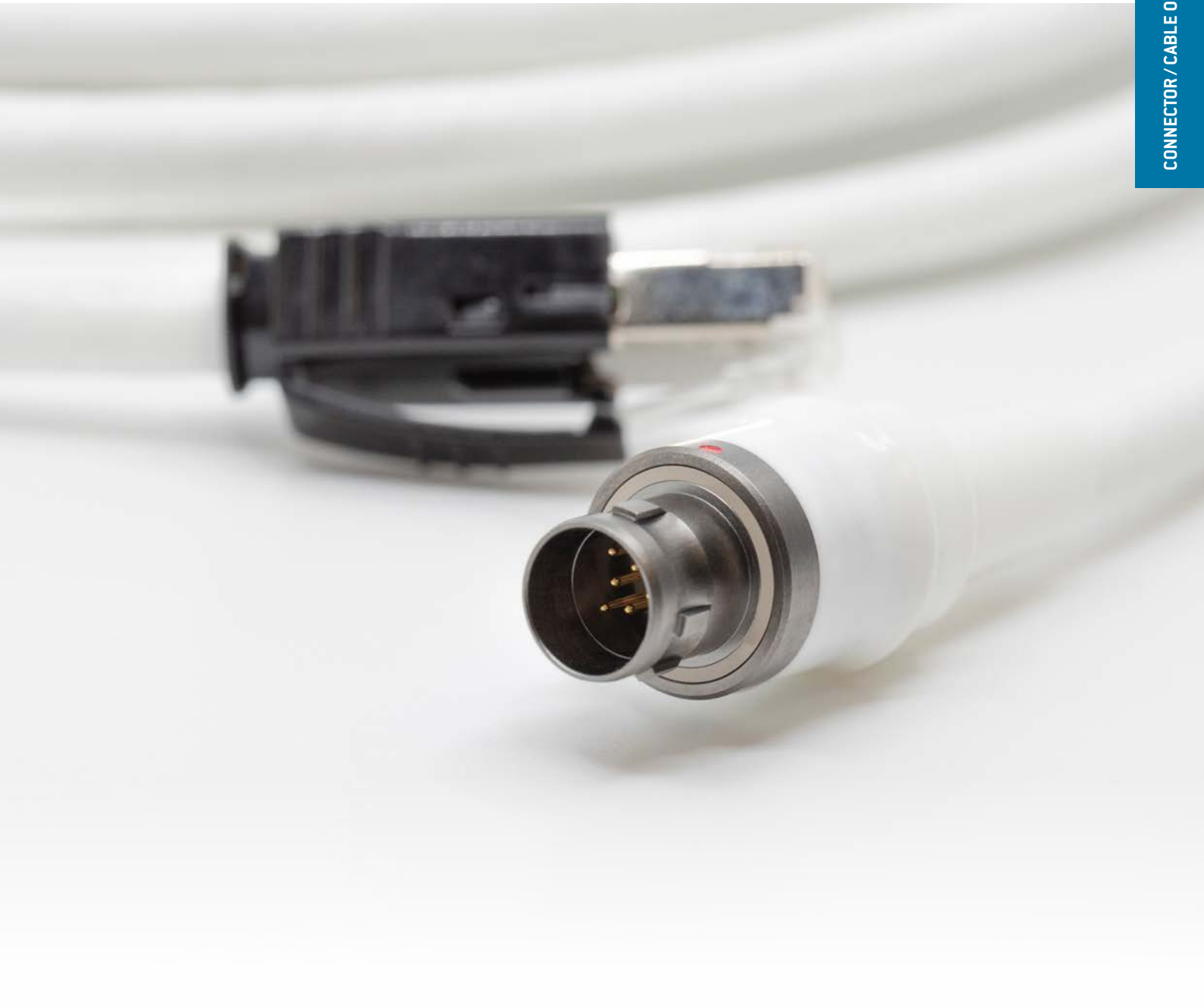

DATA CABLES HDMI® 2.0

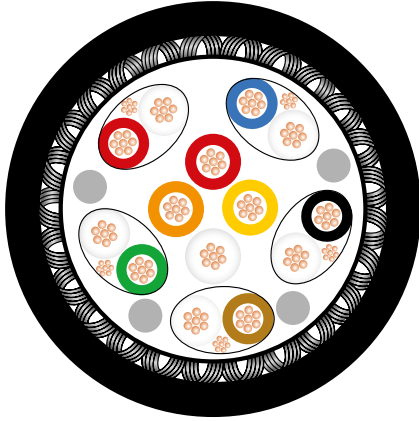

| TECHNICAL DATA | PRE-ASSEMBLED |
|-------------------|----------------------------|
| Conductor | Stranded copper wire |
| Composition | 5 x 2 x AWG30 4 x AWG30 |
| UL-Style | 20276 |
| Jacket / Color | PVC / Black |
| Temperature range | -20 up to +80 °C |
| Test voltage | 300 V/AC |

DATA CABLES HDMI® 2.1

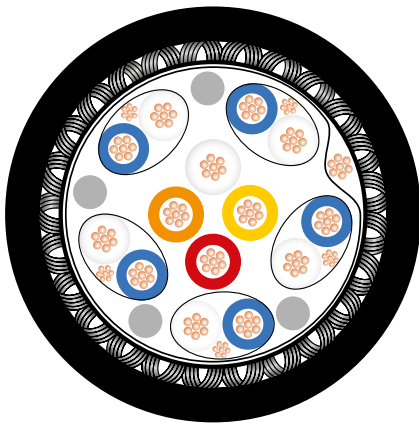

| TECHNICAL DATA | PRE-ASSEMBLED |
|-------------------|--|
| Conductor | Stranded copper wire |
| Composition | Length 1 m / 2 m: 5 x 2 x AWG30 4 x AWG30 Length 3 m: 5 x 2 x AWG30 4 x AWG28 |
| UL-Style | 20276 |
| Jacket / Color | PVC / Black |
| Temperature range | -20 up to +80 °C |
| Test voltage | 300 V/AC |

DATA CABLES DISPLAYPORT® 2.0

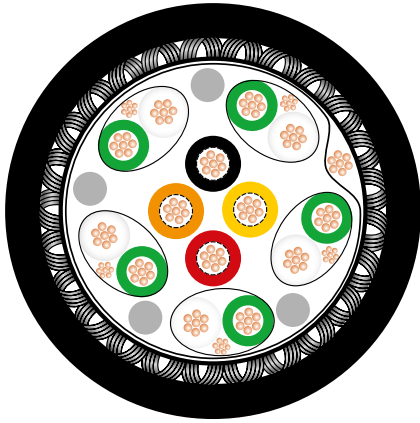

TECHNICAL DATA

| | |
|-------------------|----------------------------|
| Conductor | Stranded copper wire |
| Composition | 5 x 2 x AWG30 4 x AWG30 |
| UL-Style | 20276 |
| Jacket / Color | PVC / Black |
| Temperature range | -20 up to +80 °C |
| Test voltage | 300 V/AC |

PRE-ASSEMBLED



DATA CABLES USB® 2.0

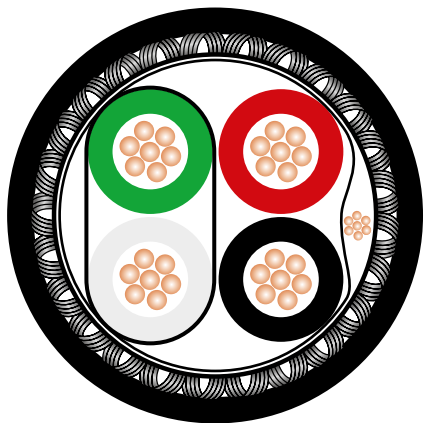

TECHNICAL DATA

| | BY THE METER | PRE-ASSEMBLED – TYPE A |
|-------------------|------------------------------|------------------------------|
| Conductor | Stranded tinned copper wire | Stranded copper wire |
| Composition | 1 x 2 x AWG 28 2 x AWG 28 | 1 x 2 x AWG 28 2 x AWG 24 |
| Jacket / Color | TPU / Black | PVC / Black |
| Temperature range | -30 up to 80 °C | -15 up to +80 °C |
| Test voltage | 100 V | |

DATA CABLES USB® 3.2 GEN 1x1

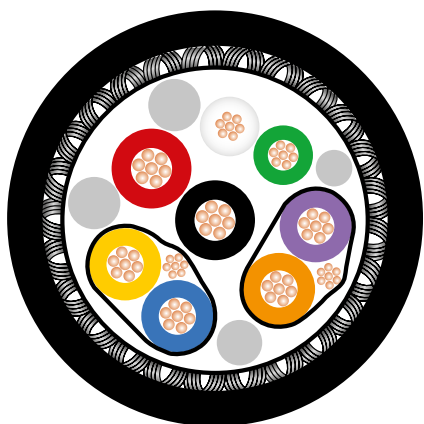

TECHNICAL DATA

| | BY THE METER | PRE-ASSEMBLED – TYPE A |
|-------------------|--|------------------------|
| Conductor | Stranded tinned copper wire | Stranded copper wire |
| Composition | 2 x 2 x AWG 28 1 x 2 x AWG 28 2 x AWG 24 | |
| UL-Style | 20963 | 20276 |
| Jacket / Color | PUR / Black | PVC / Black |
| Temperature range | -40 up to 80 °C | -15 up to +80 °C |
| Test voltage | 500 V | 300 V |

DATA CABLES USB® 3.2 GEN 2x2

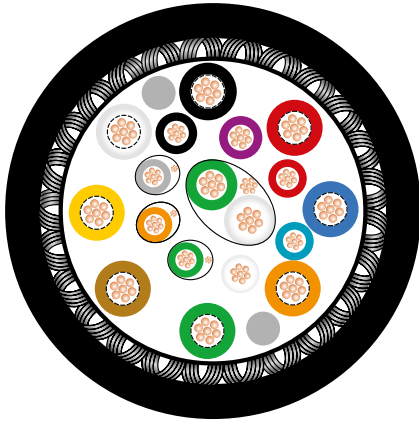

TECHNICAL DATA

| | PRE-ASSEMBLED –TYPE C PLUG (PASSIVE) |
|-----------------------------|--|
| Conductor | Stranded copper wire |
| Composition | 8 x AWG 30 / Coaxial 1 x 2 x AWG 30 2 x AWG 28 3 x AWG 30 3 x AWG 30 / Foil shield |
| UL-Style | 758 |
| Jacket / Color | TPE / Black |
| Temperature range | -20 up to +85 °C |
| Temperature range at motion | ±0 up to +50 °C |
| Test voltage | 300 V |



CONNECTOR LOCKING AND STYLE OPTIONS

- Miniaturized and light weight
- Watertight with IP68 and IP69
- Optimized mechanical and optical color coding
- Long lifetime with over 5000 mating cycles
- Blind mating and demating in difficult-to-reach places

ODU AMC®

available with DP / HDMI® / Ethernet® / USB®

| Pos. 2-3 | PLUGS |
|----------|---|
| S1 | Push-pull  |
| A1 | Break-away  |

| Pos. 2-3 | RECEPTACLE |
|----------|---|
| K1 | In-line receptacle  |
| G6 | Panel mount receptacle  |

ODU AMC® High-Density

available with HDMI® / Ethernet® / USB®

| | |
|----|---|
| A1 | Break-away  |
| C1 | Screw  |

| | |
|----|---|
| G6 | Panel mount receptacle  |
| K1 | In-line receptacle  |
| KC | In-line receptacle with screw-lock  |
| GS | Panel mount receptacle with screw-lock  |

ODU AMC® SERIES T

available with DP / HDMI® / Ethernet®
Serie-T 38999 certified

| | |
|----|--|
| S1 | Push-Pull  |
| A1 | Break-away  |
| C1 | Screw locking  |

| | |
|----|---|
| K1 | In-line receptacle  |
| G6 | Panel mount receptacle  |

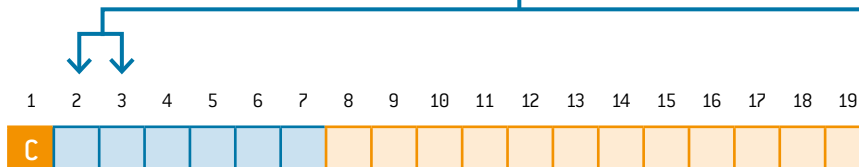



ODU MINI-SNAP® SERIES L

available with DP / HDMI® / Ethernet® / USB®

- Quick and easy mating and demating
- Low space requirements on the receptacles
- Definite and secure locking conditions
- IP50

| Pos. 2-3 | PLUGS |
|----------|---|
| S1 | Push-pull  |
| S2 | Push-pull  |
| A1 | Break-away  |
| A2 | Break-away  |

| Pos. 2-3 | RECEPTACLE |
|----------|---|
| K1 | In-line receptacle  |
| G6 | Panel mount receptacle  |

ODU MINI-SNAP® SERIES K

available with DP / HDMI® / Ethernet® / USB®

- Quick and easy mating and demating
- Low space requirements on the receptacles
- Definite and secure locking conditions
- IP68

| | |
|----|---|
| S1 | Push-pull  |
| S2 | Push-pull  |
| A1 | Break-away  |
| A2 | Break-away  |

| | |
|-------|---|
| K1 | In-line receptacle  |
| K2 | In-line receptacle  |
| G6/GB | Panel mount receptacle  |

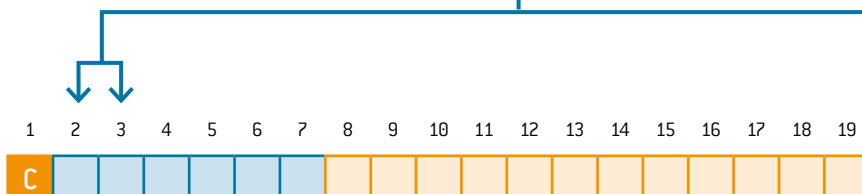

CONNECTOR CODING AND PLATING



| ODU MINI-SNAP® Series L | | | | | | | | |
|-------------------------|-------|-----------------------|------|---|---|---|---|---|
| Pos. 6 | Angle | Receptacle front view | Size | | | | | |
| | | | 00 | 0 | 1 | 2 | 3 | 4 |
| 0 | 0° | | • | • | • | • | • | • |
| A | 30° | | • | • | • | • | • | |
| C | 45° | | | | | • | • | |
| C | -45° | | • | • | • | | | |
| F | 60° | | • | • | • | • | • | |

| ODU MINI-SNAP® Series K | | | | | | | |
|-------------------------|-------|-----------------------|------|---|---|---|---|
| Pos. 6 | Angle | Receptacle front view | Size | | | | |
| | | | 0 | 1 | 2 | 3 | 4 |
| 0 | 0° | | • | • | • | • | • |
| A | 30° | | • | • | • | • | |
| C | 45° | | • | • | • | | |
| F | 60° | | • | • | • | | |

| ODU AMC® Y/T/HD | | |
|-----------------|-----------------|-------------|
| Pos. 6 | Plug front view | Color |
| A | | Light brown |
| B | | Red |
| C | | Blue |
| D | | Green |

| ODU MINI-SNAP® Series L/K | | |
|---------------------------|------------|--------------|
| Pos. 7 | Plating | |
| C | Standard | Matte chrome |
| Z | On request | Tin-nickel |

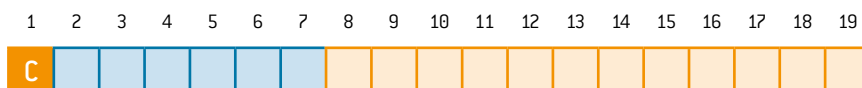

Further codings are available on request.

COLOR OPTION



| Color bend relief ODU MINI-SNAP® Series L / K | | |
|---|---------------------|---------------|
| Pos. 10-11 | Bend-/strain relief | Color (RAL) |
| 10 | Standard backnut | Gray |
| 3A | Silicon bend relief | Red (3020) |
| 3B | | White (9010) |
| 3C | | Yellow (1016) |
| 3D | | Green (6029) |
| 3E | | Blue (5002) |
| 3F | | Gray (7005) |
| 3G | | Black (9005) |
| 4B | Overmolding | White (9010) |
| 4F | | Gray (7005) |
| 4G | | Black (9005) |
| Color bend relief ODU AMC® | | |
| Pos. 10-11 | Bend-/strain relief | Color (RAL) |
| 4I | Overmolding | Black (9005) |

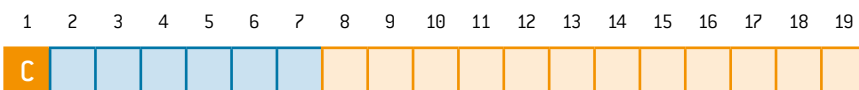

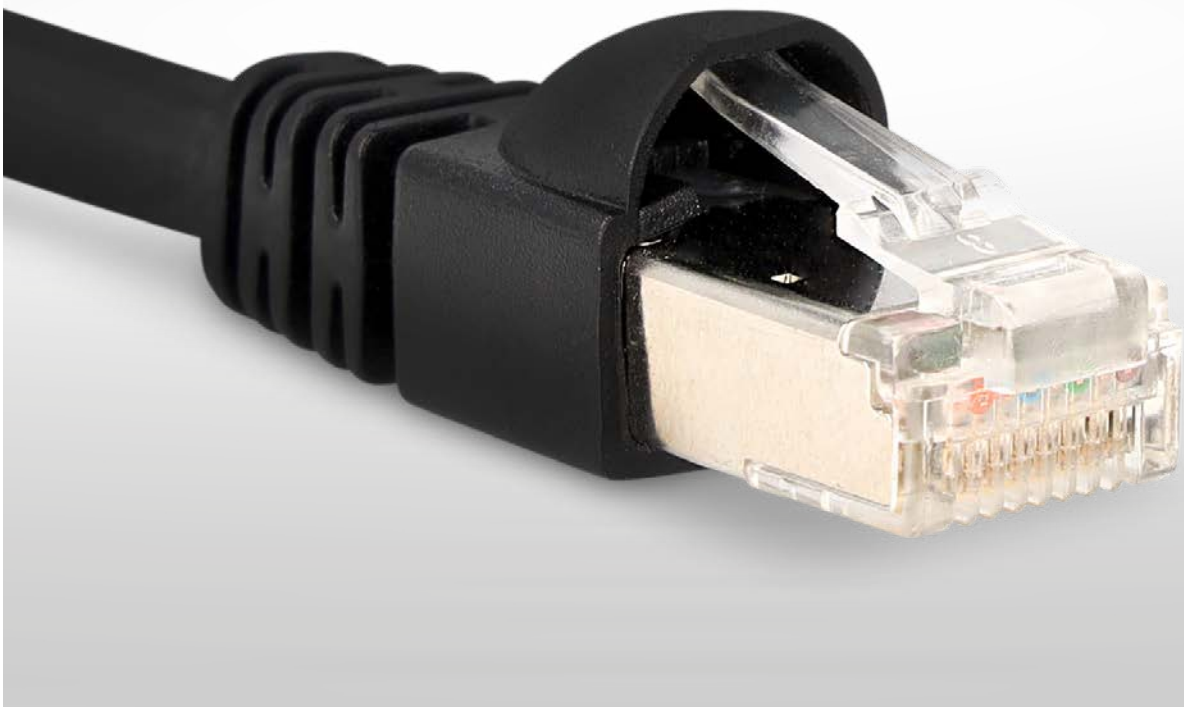

Ethernet® is the most widely used local area network (LAN) technology that allows devices to communicate with each other using a protocol – a set of rules or a common network language. Ethernet® is a data link layer protocol in the TCP / IP stack that describes how network devices can send and receive data packages so that other devices in the same local or site network segment can find, receive, and process them.

An Ethernet® cable is the physical, encapsulated line over which the data is transmitted. Compared to the Wi-Fi technology, Ethernet® is generally less susceptible to interference – whether from radio wave interference nor physical barriers. It can also provide a greater level of network security and control than wireless technology because the devices need to be connected via physical cables. This makes it difficult for outsiders to access network data or hijack bandwidth for unauthorized devices.

The maximum channel length for Ethernet® class EA is 100 meters.

High-speed data technology cable assemblies



ETHERNET/IP® UP TO 10 GBIT/S

| | |
|-------------------------------|--------------------|
| ODU AMC® | 18 |
| ODU AMC® High-Density | 19 |
| ODU AMC® Series T | 20 |
| ODU-MAC® Blue-Line | 21 |
| ODU MINI-SNAP® Series L | 22 |
| ODU MINI-SNAP® Series K | 24 |

ODU AMC®

Ethernet® up to 25000 mm per single side assembly

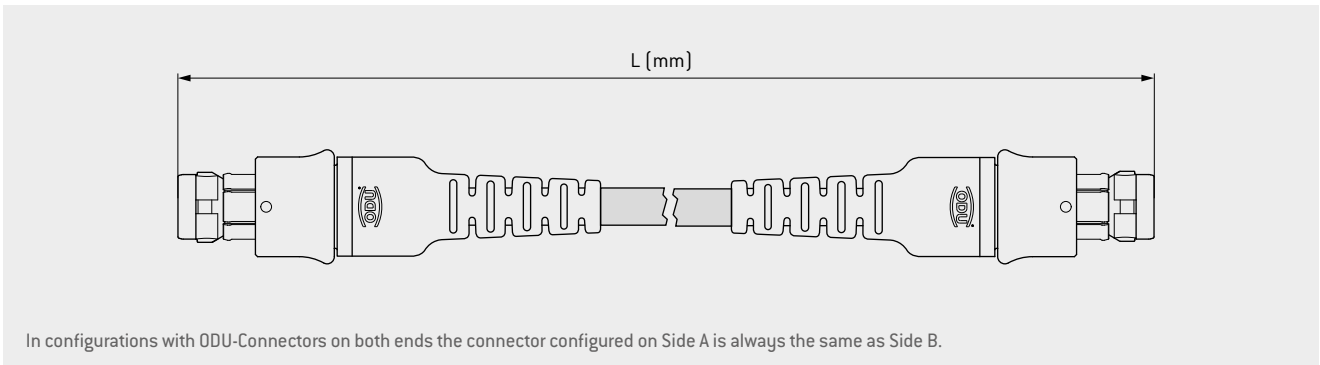
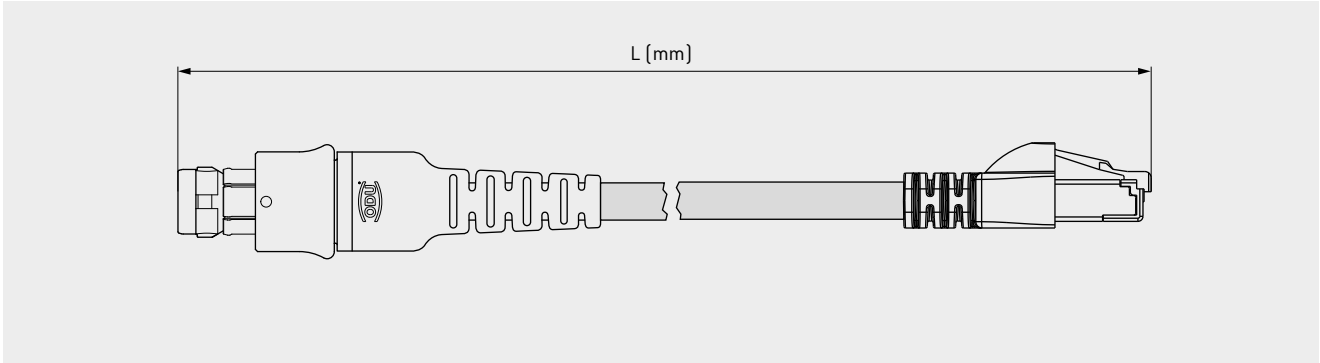

| Pos. 2-3 | Connector type |
|----------|------------------------|
| A1 | Break-away plug |
| S1 | Push-pull plug |
| K1 | In-line receptacle |
| G6 | Panel mount receptacle |

| Pos. 4 | Size | Data rate* | Pin/Socket | 2 nd side | Pos. 12-13 |
|--------|------|------------|------------|----------------------|------------|
| 1 | 1 | 1 Gbit/s | Pin | RJ45 | Y0 |
| | | | Socket | RJ45 | YR |
| A | 1.5 | 1 Gbit/s | Pin | RJ45 | YI |
| | | | Socket | RJ45 | YG |
| 2 | 2 | 10 Gbit/s | Pin | RJ45 | YL |
| | | | Socket | RJ45 | YJ |
| | | | | | YK |

| Pos. 6 | Coding |
|--------|-------------|
| A | Light brown |
| B | Red |
| C | Blue |
| D | Green |

| Pos. 14-19 | Length |
|--|--------|
| Length L of assembly in mm (minimum cable length 300 mm) Example: 1000 mm = 001000 | |

1 2 3 4 5 6 7 8 9 10 11 12 13 14 15 16 17 18 19

C Y R 0 8 4 I

*Data rates mentioned are based on the respective standard data transmission protocol and are determined by connector size.

ODU AMC® HIGH-DENSITY

Ethernet® up to 25000 mm per single side assembly

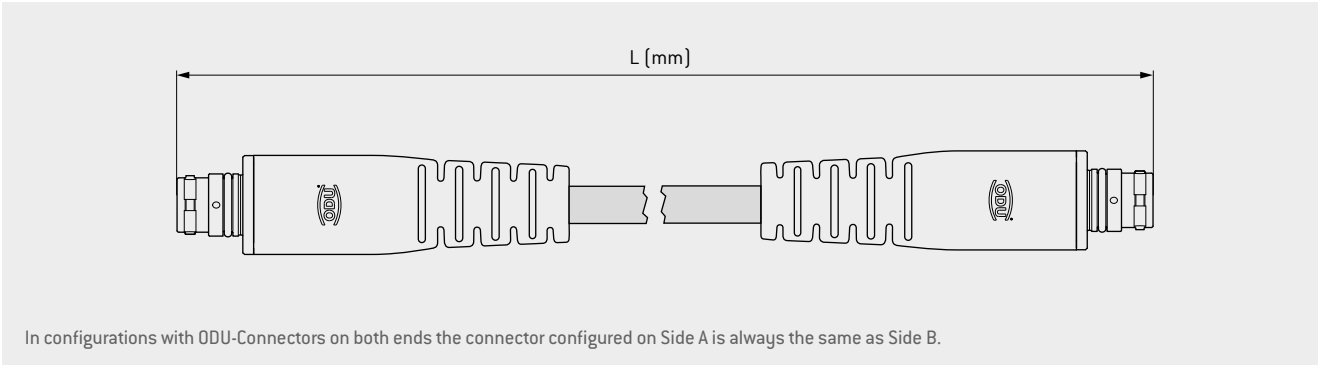
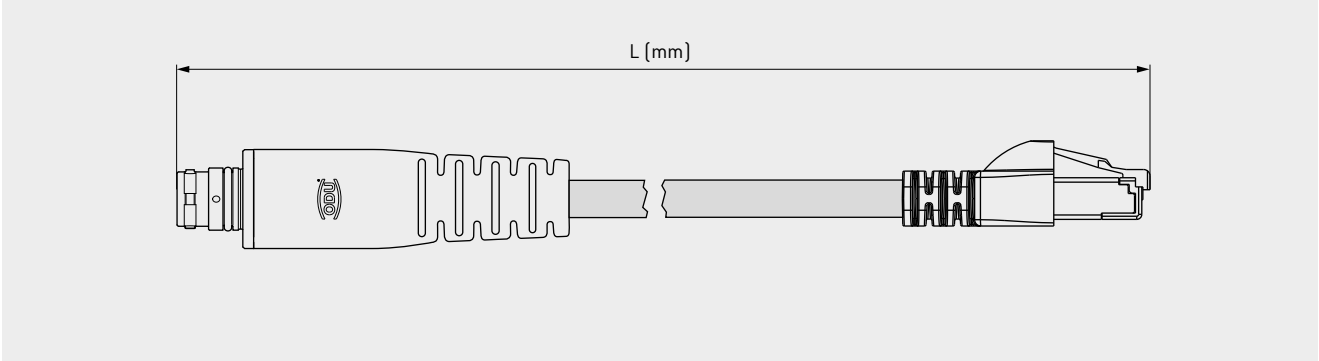

| Pos. 2-3 | Connector type |
|----------|--|
| A1 | Break-away plug |
| C1 | Threaded plug |
| K1 | In-line receptacle |
| G6 | Panel mount receptacle |
| KC | In-line receptacle with screw-lock |
| GS | Panel mount receptacle with screw-lock |

| Pos. 6 | Coding |
|--------|-------------|
| A | Light brown |
| B | Red |
| C | Blue |
| D | Green |

| Data rate | Pin/Socket | 2 nd side | Pos. 12-13 |
|-----------|------------|----------------------|------------|
| 10 Gbit/s | Pin | RJ45 | YL |
| | | ODU | YJ |
| | Socket | RJ45 | YK |

| Pos. 14-19 | Length |
|--|--------|
| Length L of assembly in mm (minimum cable length 300 mm) Example: 1000 mm = 001000 | |

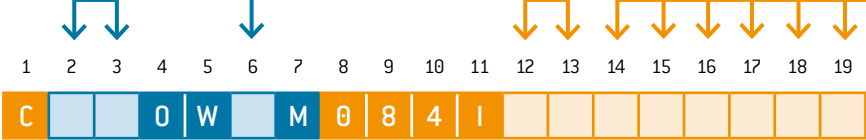

*Data rates mentioned are based on the respective standard data transmission protocol.

ODU AMC® SERIES T

Ethernet® up to 25000 mm per single side assembly

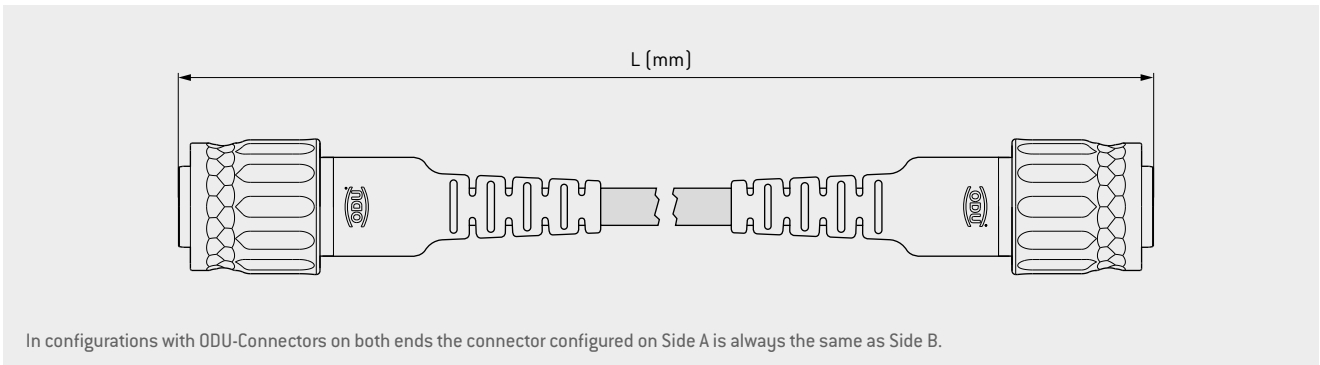
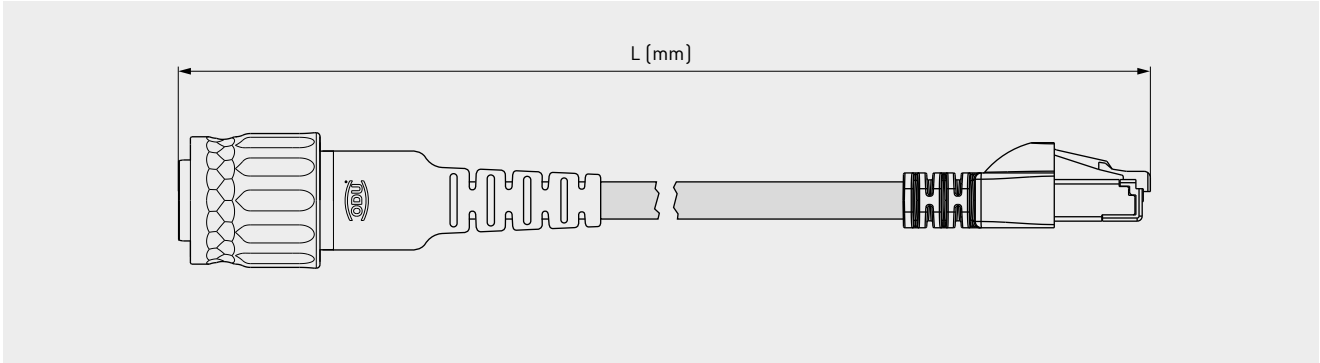

| Pos. 2-3 | Connector type |
|----------|------------------------|
| A1 | Break-away plug |
| S1 | Push-pull plug |
| C1 | Threaded plug |
| K1 | In-line receptacle |
| G6 | Panel mount receptacle |

| Data rate* | Pin/Socket | 2 nd side | Pos. 12-13 |
|------------|------------|----------------------|------------|
| 10 Gbit/s | Pin | RJ45 | ZJ |
| | | ODU | ZH |
| 10 Gbit/s | Socket | RJ45 | ZI |

| Pos. 6 | Coding |
|--------|-------------|
| A | Light brown |
| B | Red |
| C | Blue |
| D | Green |

| Pos. 14-19 | Length |
|--|--------|
| Length L of assembly in mm (minimum cable length 300 mm) Example: 1000 mm = 001000 | |



*Data rates mentioned are based on the respective standard data transmission protocol.

ODU-MAC® BLUE-LINE

Ethernet® up to 5000 mm per single side assembly

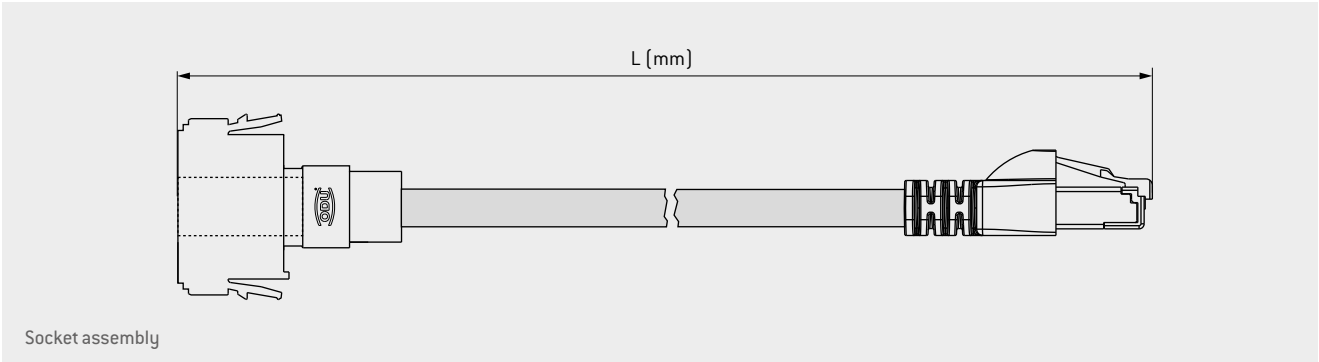
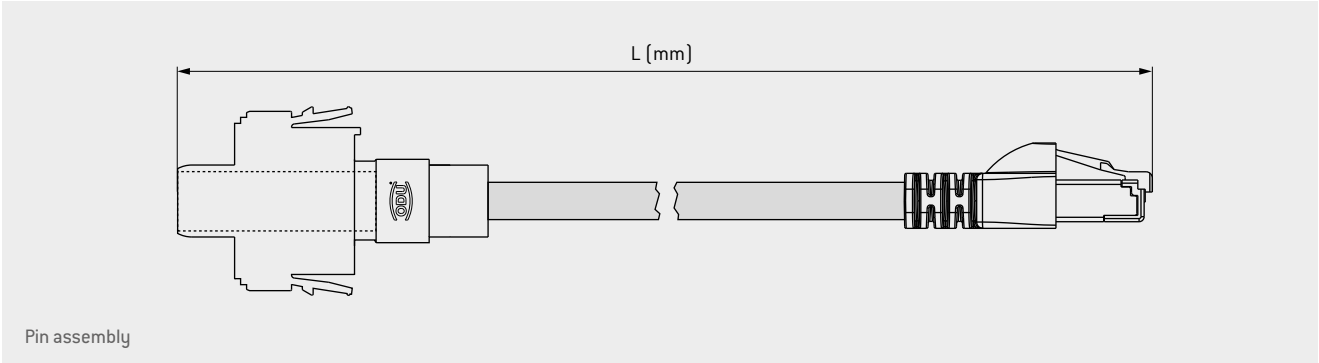

| Pos. 2 | Pin/Socket |
|--------|------------|
| P | Pin |
| S | Socket |

| Data rate* | Module units | Number of inserts | Pos. 8-9 | 2 nd side | Pos. 12-13 |
|------------|--------------|-------------------|----------|----------------------|------------|
| 10 Gbit/s | 7 | 1 | 01 | RJ45 | WZ |
| 1 Gbit/s | 6 | 2 | 02 | RJ45 | WZ |

| Pos. 16-19 | Length |
|--|--------|
| Length L of assembly in mm (minimum cable length 300 mm) Example: 1000 mm = 1000 | |

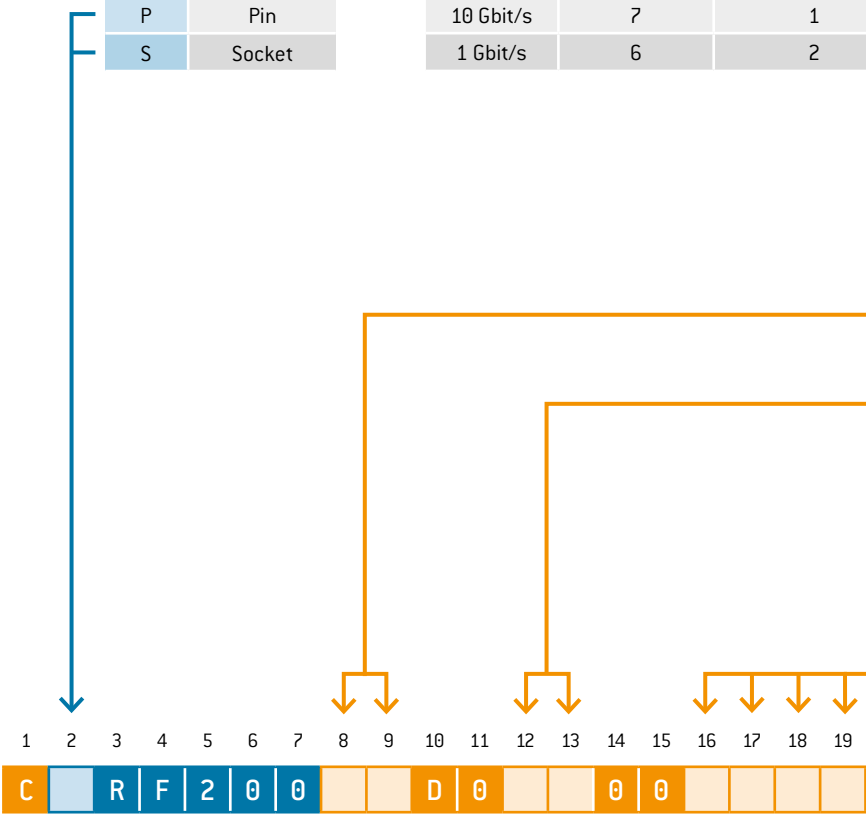

*Data rates mentioned are based on the respective standard data transmission protocol.

ODU MINI-SNAP® SERIES L

Ethernet® without bend relief up to 25000 mm per single side assembly

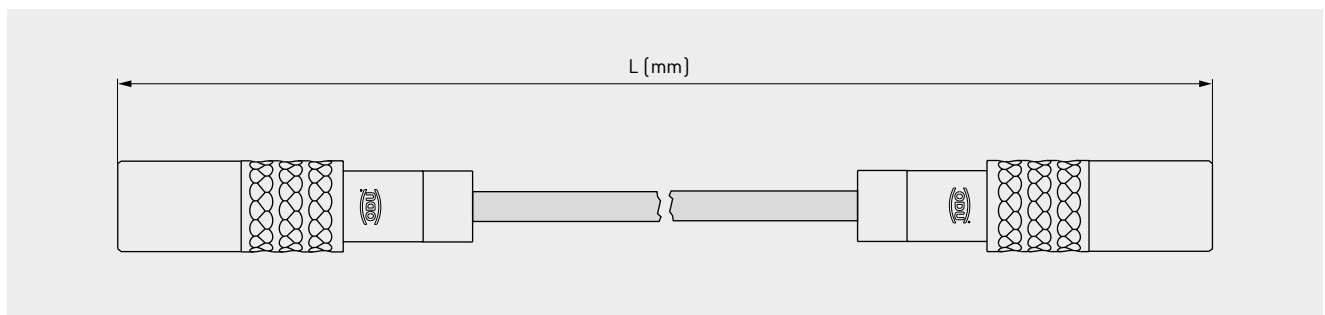
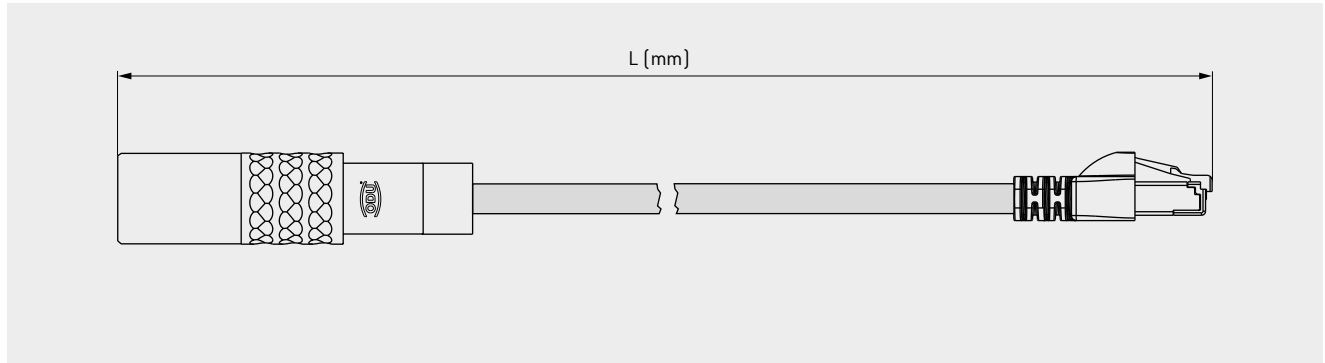

In configurations with ODU-Connectors on both ends the connector configured on Side A is always the same as Side B.

| Pos. 2-3 | Connector type |
|----------|------------------------|
| A1 | Break-away plug |
| S1 | Push-pull plug |
| K1 | In-line receptacle |
| G6 | Panel mount receptacle |

| Pos. 4 | Size | Data rate* | Pin/Socket | 2 nd side | Pos. 12-13 |
|--------|------|------------|------------|----------------------|------------|
| 1 | 1 | 1 Gbit/s | Pin | RJ45 | VZ |
| | | | Socket | RJ45 | VX |
| 2 | 2 | 10 Gbit/s | Pin | RJ45 | VW |
| | | | Socket | RJ45 | VU |

The available codings for the respective series can be found on page 14.

| Pos. 7 | Housing surface |
|--------|-----------------|
| C | Matte chrome |
| Z | Tin-nickel |

| Pos. 14-19 | Length |
|---|--------|
| Length L of assembly in mm (minimum cable length 300 mm) Example: 1000 mm = 001000 | |



*Data rates mentioned are based on the respective standard data transmission protocol and are determined by connector size.

ODU MINI-SNAP® SERIES L

Ethernet® with bend relief up to 25000 mm per single side assembly

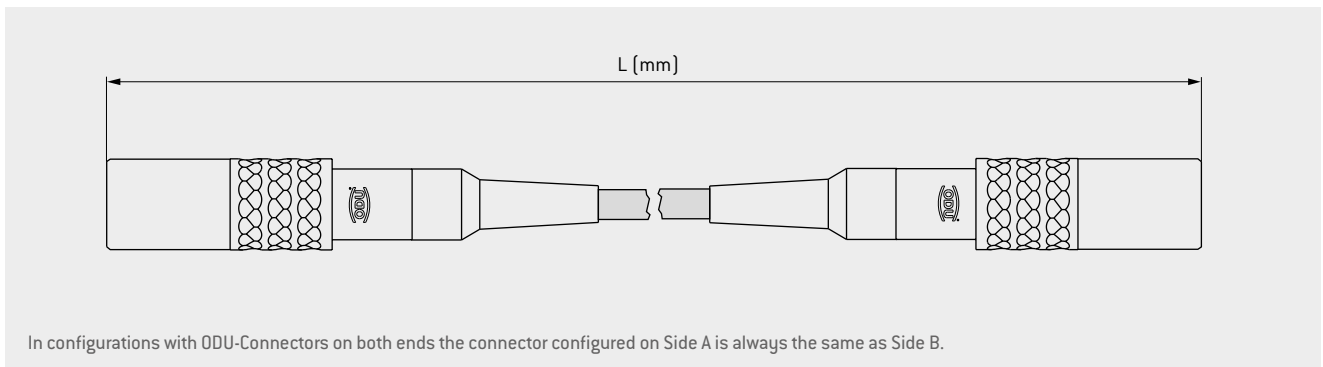
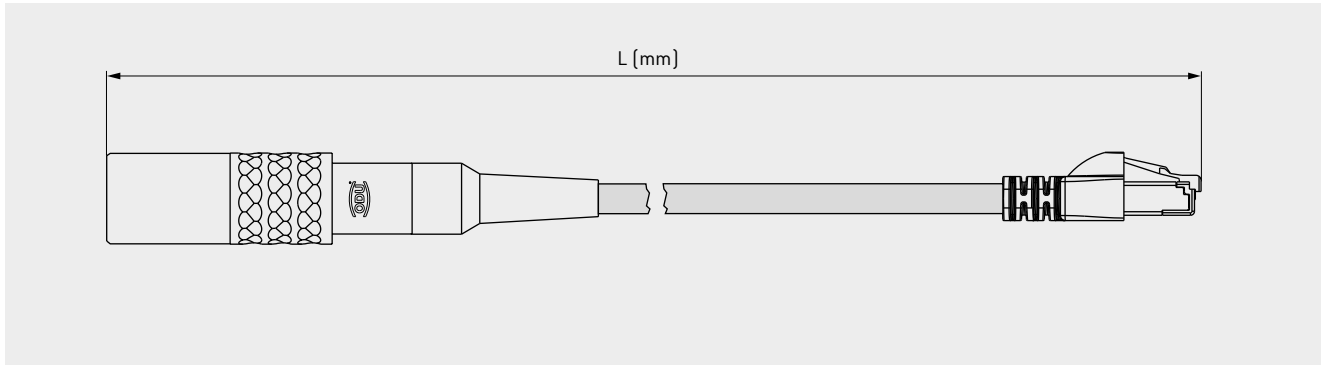

| Pos. 2-3 | Connector type |
|----------|--------------------|
| A2 | Break-away plug |
| S2 | Push-pull plug |
| K2 | In-line receptacle |

| Pos. 4 | Size | Data rate* | Pin/Socket | 2 nd side | Pos. 12-13 |
|--------|------|------------|------------|----------------------|------------|
| 1 | 1 | 1 Gbit/s | Pin | RJ45 | VZ |
| | | | Socket | RJ45 | VX |
| 2 | 2 | 10 Gbit/s | Pin | RJ45 | VW |
| | | | Socket | RJ45 | VU |

The available codings for the respective series can be found on page 14.

| Pos. 7 | Housing surface |
|--------|-----------------|
| C | Matte chrome |
| Z | Tin-nickel |

The available color of the bend and strain relief can be found on page 15.

| Pos. 14-19 | Length |
|---|--------|
| Length L of assembly in mm (minimum cable length 300 mm) Example: 1000 mm = 001000 | |

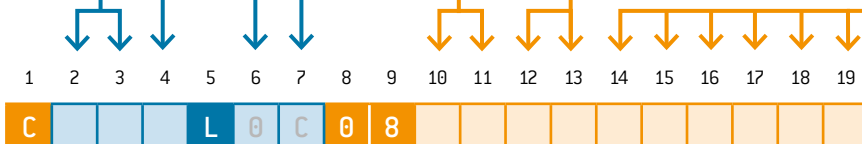

*Data rates mentioned are based on the respective standard data transmission protocol and are determined by connector size.

ODU MINI-SNAP® SERIES K

Ethernet® without bend relief up to 25000 mm per single side assembly

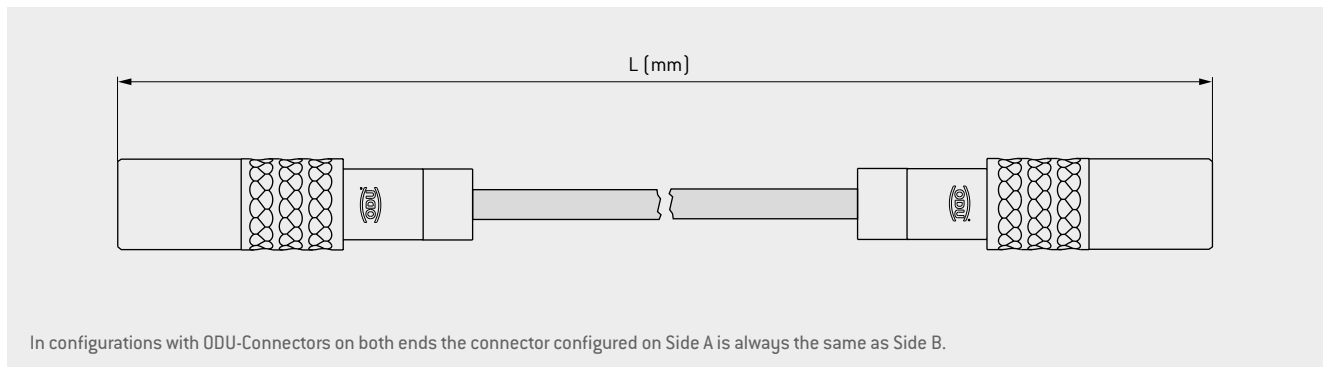
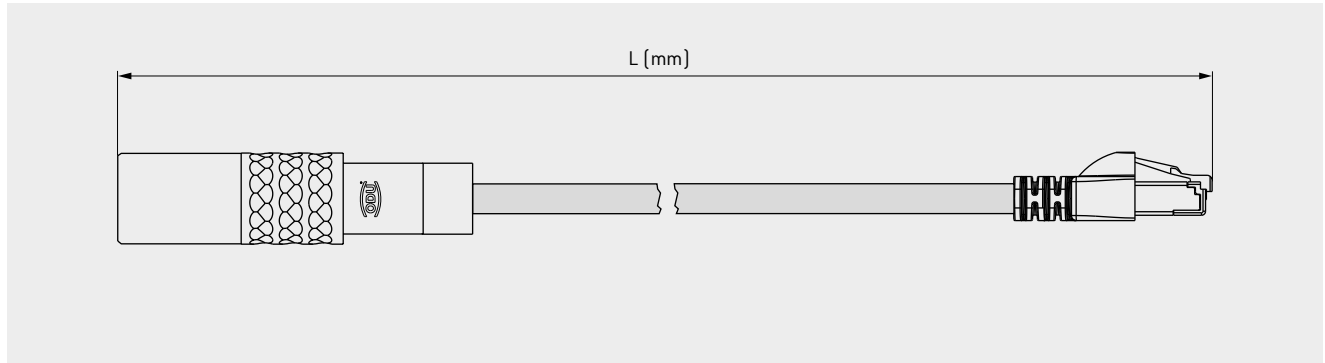

| Pos. 2-3 | Connector type |
|----------|--------------------------------|
| SA | Push-pull plug, Size 1 |
| KA | In-line receptacle, Size 1 |
| GB | Panel mount receptacle, Size 1 |
| S1 | Push-pull plug, Size 2 |
| K1 | In-line receptacle, Size 2 |
| G6 | Panel mount receptacle, Size 2 |

| Pos. 4 | Size | Data rate* | Pin/Socket | 2 nd side | Pos. 12-13 |
|--------|------|------------|------------|----------------------|------------|
| 1 | 1 | 1 Gbit/s | Pin | RJ45 | VZ |
| | | | Socket | RJ45 | VX |
| 2 | 2 | 10 Gbit/s | Pin | RJ45 | VW |
| | | | Socket | RJ45 | VU |

The available codings for the respective series can be found on page 14.

| Pos. 7 | Housing surface |
|--------|-----------------|
| C | Matte chrome |
| Z | Tin-nickel |

| Pos. 14-19 | Length |
|---|--------|
| Length L of assembly in mm (minimum cable length 300 mm) Example: 1000 mm = 001000 | |



*Data rates mentioned are based on the respective standard data transmission protocol and are determined by connector size.

ODU MINI-SNAP® SERIES K

Ethernet® with bend relief up to 25000 mm per single side assembly

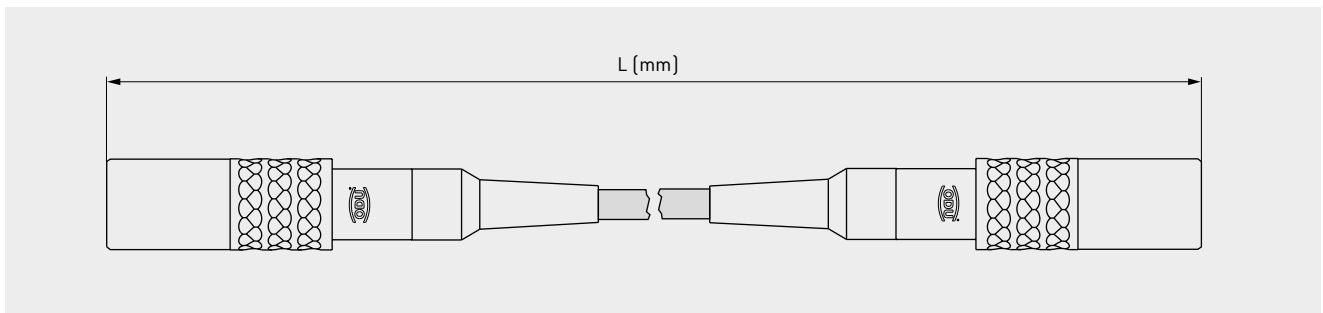
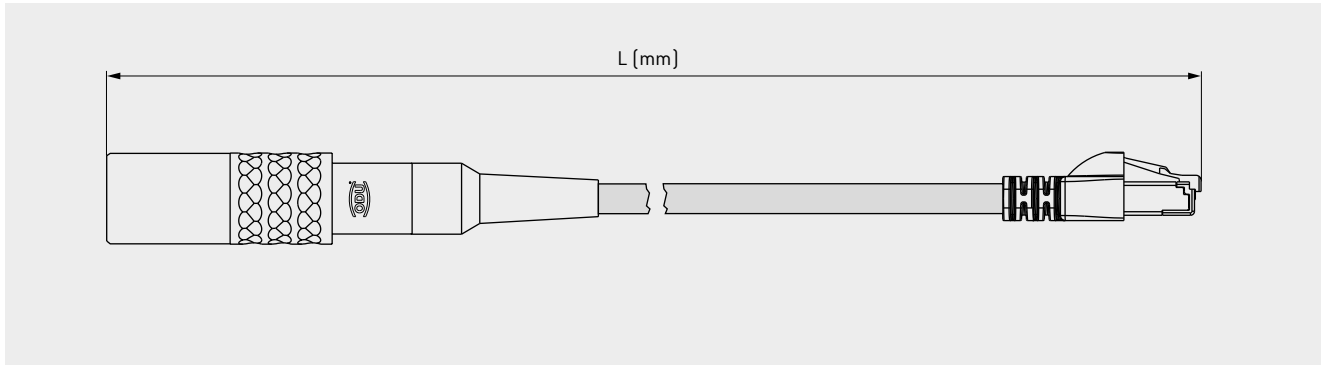

In configurations with ODU-Connectors on both ends the connector configured on Side A is always the same as Side B.

| Pos. 2-3 | Connector type |
|----------|----------------------------|
| SB | Push-pull plug, Size 1 |
| KB | In-line receptacle, Size 1 |
| S2 | Push-pull plug, Size 2 |
| K2 | In-line receptacle, Size 2 |

| Pos. 4 | Size | Data rate* | Pin/Socket | 2 nd side | Pos. 12-13 |
|--------|------|------------|------------|----------------------|------------|
| 1 | 1 | 1 Gbit/s | Pin | RJ45 | VZ |
| | | | Socket | ODU | VY |
| 2 | 2 | 10 Gbit/s | Pin | RJ45 | VW |
| | | | Socket | ODU | VV |
| | | | | RJ45 | VU |

The available codings for the respective series can be found on page 14.

| Pos. 7 | Housing surface |
|--------|-----------------|
| C | Matte chrome |
| Z | Tin-nickel |

The available color of the bend and strain relief can be found on page 15.

| Pos. 14-19 | Length |
|---|--------|
| Length L of assembly in mm (minimum cable length 300 mm) Example: 1000 mm = 001000 | |

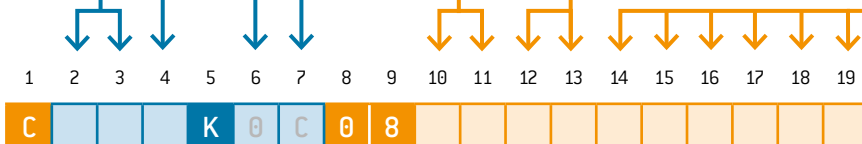

*Data rates mentioned are based on the respective standard data transmission protocol and are determined by connector size.



SPE transmits its data via one twisted pair and is nearly as capable transmission wise as Multi Pair Ethernet®. Due to the simplified design, SPE is more compact and requires less effort during installation. The key to the challenges of the industrial production of the future lies in fast access to data and seamless communication from the sensor to the cloud. Connect your devices via Single Pair Ethernet®. There is no other future-proof network technology that offers comparable performance and benefits. Single Pair Ethernet® revolutionizes the market: In the long term, SPE will replace classic serial bus systems. Single-pair data cabling is innovative and efficient. With its seamless communication, SPE is paving the way for the Industrial Internet of Things (IIoT) and Industry 4.0.

The maximum channel length for SPE Link Segment B acc. to IEEE 802.3bp is 40 meters whereas it is 15m for IEEE 802.3ch.

High-speed data technology cable assemblies

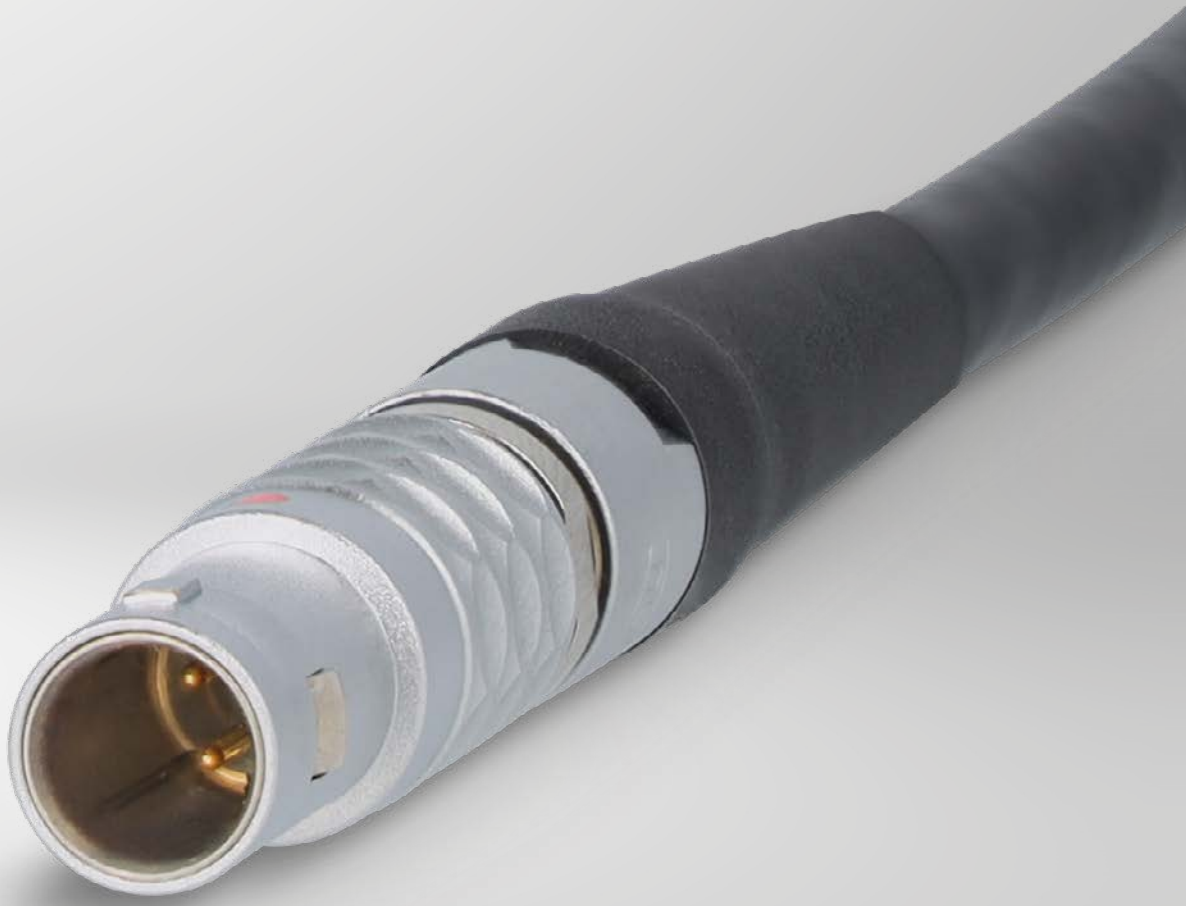

SPE UP TO 10 GBIT/S

| | |
|-------------------------------|--------------------|
| ODU MINI-SNAP® Series L | 28 |
| ODU MINI-SNAP® Series K | 30 |
| ODU-MAC® Blue-Line | 32 |

ODU MINI-SNAP® SERIES L

SPE without bend relief up to 15000 mm per single side assembly

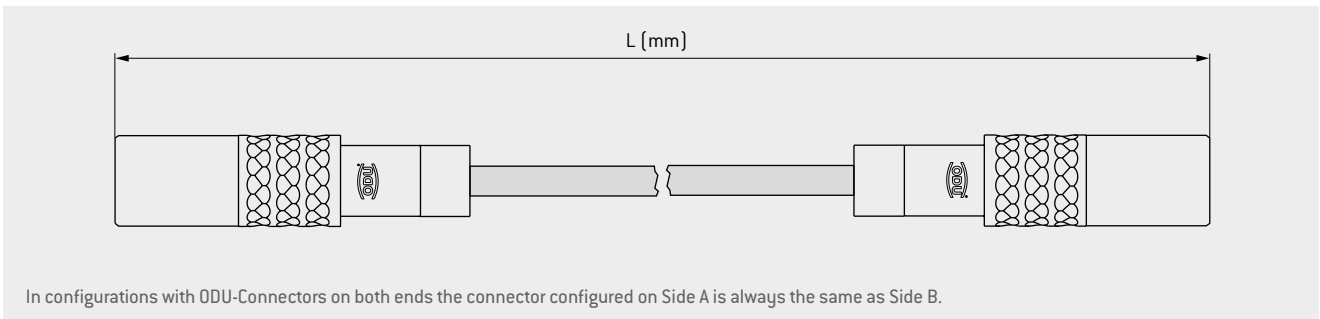
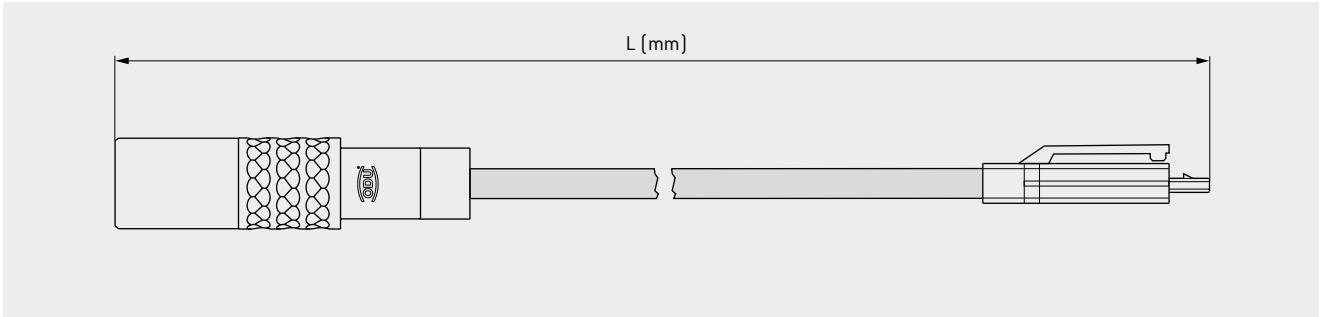

In configurations with ODU-Connectors on both ends the connector configured on Side A is always the same as Side B.

| Pos. 2-3 | Connector type |
|----------|------------------------|
| A1 | Break-away plug |
| S1 | Push-pull plug |
| K1 | In-line receptacle |
| G6 | Panel mount receptacle |

| Data rate* | Pin/Socket | 2 nd side | Pos. 12-13 |
|------------|------------|----------------------|------------|
| 1 Gbit/s | Pin | IEC 63171-2 | VA |
| 10 Gbit/s | | ODU | VB |
| 1 Gbit/s | Socket | IEC 63171-2 | V9 |

The available codings for the respective series can be found on page 14.

| Pos. 7 | Housing surface |
|--------|-----------------|
| C | Matte chrome |
| Z | Tin-nickel |

| Pos. 14-19 | Length |
|--|--------|
| Length L of assembly in mm (minimum cable length 300 mm) Example: 1000 mm = 001000 | |



*Data rates mentioned are based on the respective standard data transmission protocol.

ODU MINI-SNAP® SERIES L

SPE with bend relief up to 15000 mm per single side assembly

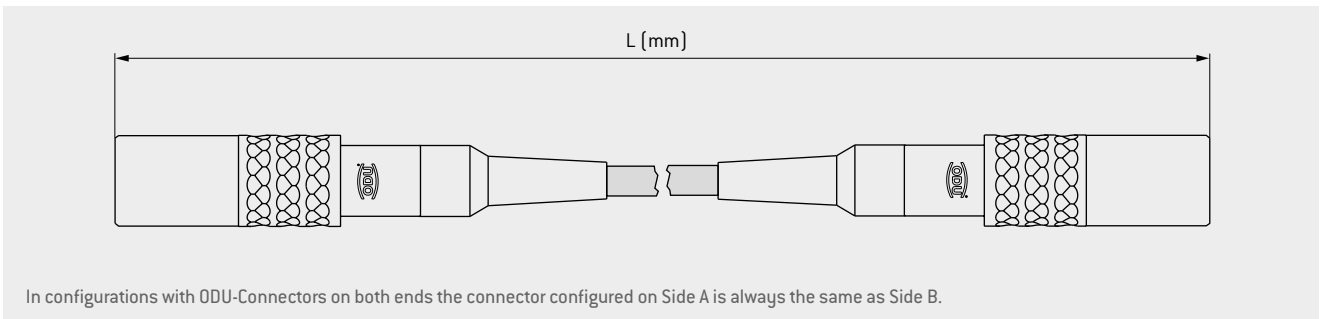
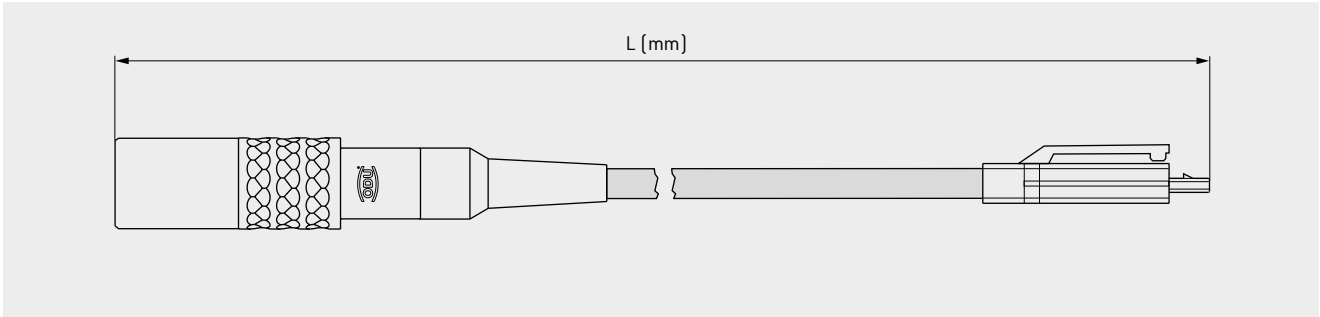

In configurations with ODU-Connectors on both ends the connector configured on Side A is always the same as Side B.

| Pos. 2-3 | Connector type |
|----------|--------------------|
| A2 | Break-away plug |
| S2 | Push-pull plug |
| K2 | In-line receptacle |

| Data rate* | Pin/Socket | 2 nd side | Pos. 12-13 |
|------------|------------|----------------------|------------|
| 1 Gbit/s | Pin | IEC 63171-2 | VA |
| 10 Gbit/s | | ODU | VB |
| 1 Gbit/s | Socket | IEC 63171-2 | V9 |

The available codings for the respective series can be found on page 14.

| Pos. 7 | Housing surface |
|--------|-----------------|
| C | Matte chrome |
| Z | Tin-nickel |

The available color of the bend and strain relief can be found on page 15.

| Pos. 14-19 | Length |
|---|--------|
| Length L of assembly in mm (minimum cable length 300 mm) Example: 1000 mm = 001000 | |

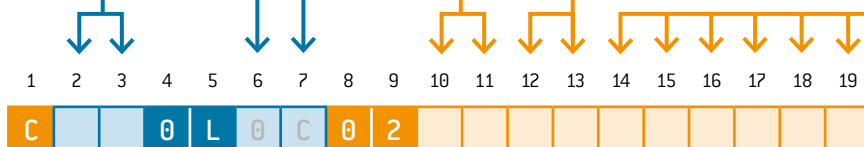

*Data rates mentioned are based on the respective standard data transmission protocol.

ODU MINI-SNAP® SERIES K

SPE without bend relief up to 15000 mm per single side assembly

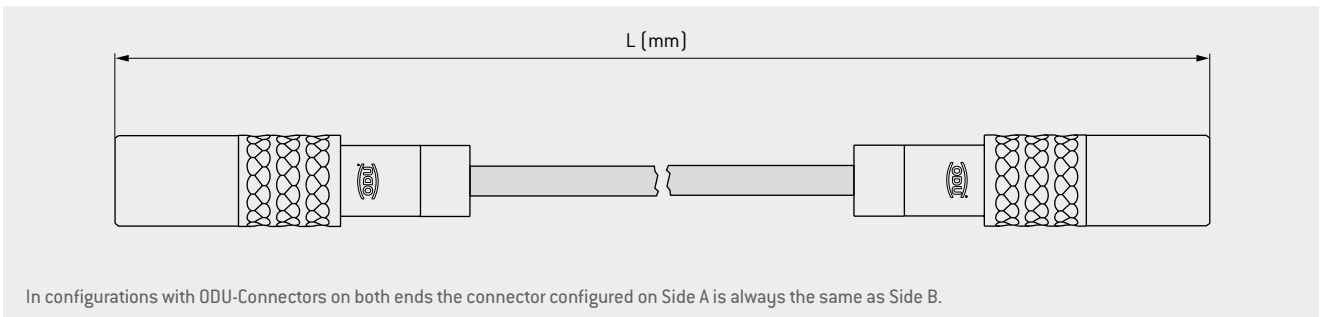
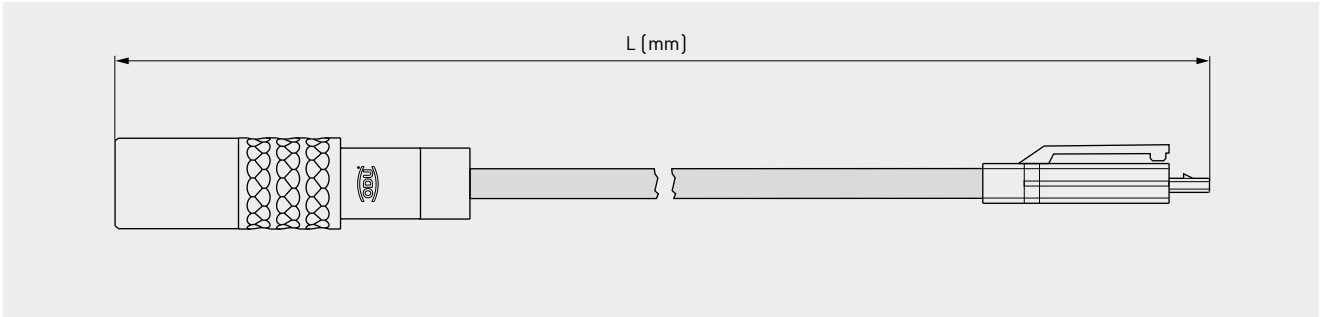

In configurations with ODU-Connectors on both ends the connector configured on Side A is always the same as Side B.

| Pos. 2-3 | Connector type |
|----------|------------------------|
| A1 | Break-away plug |
| S1 | Push-pull plug |
| K1 | In-line receptacle |
| G6 | Panel mount receptacle |

| Data rate* | Pin/Socket | 2 nd side | Pos. 12-13 |
|------------|------------|----------------------|------------|
| 1 Gbit/s | Pin | IEC 63171-2 | VA |
| 10 Gbit/s | | ODU | VB |
| 1 Gbit/s | Socket | IEC 63171-2 | V9 |

The available codings for the respective series can be found on page 14.

| Pos. 7 | Housing surface |
|--------|-----------------|
| C | Matte chrome |
| Z | Tin-nickel |

| Pos. 14-19 | Length |
|--|--------|
| Length L of assembly in mm (minimum cable length 300 mm) Example: 1000 mm = 001000 | |



*Data rates mentioned are based on the respective standard data transmission protocol.

ODU MINI-SNAP® SERIES K

SPE with bend relief up to 15000 mm per single side assembly

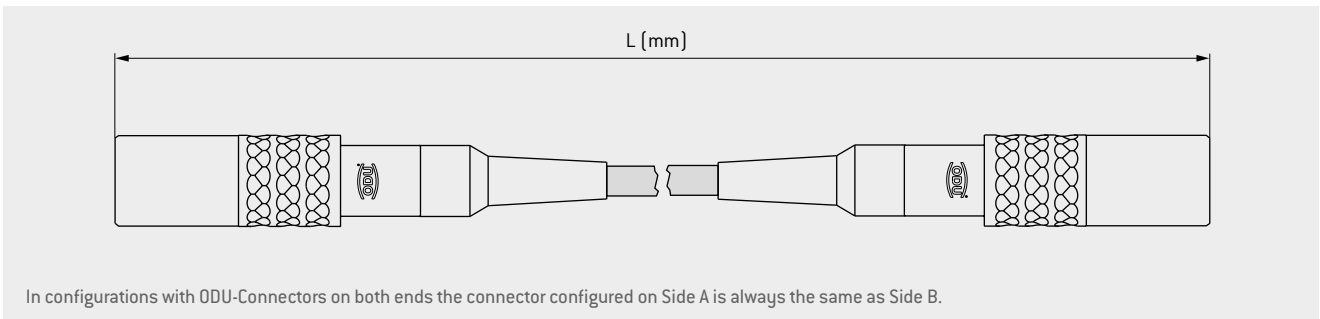
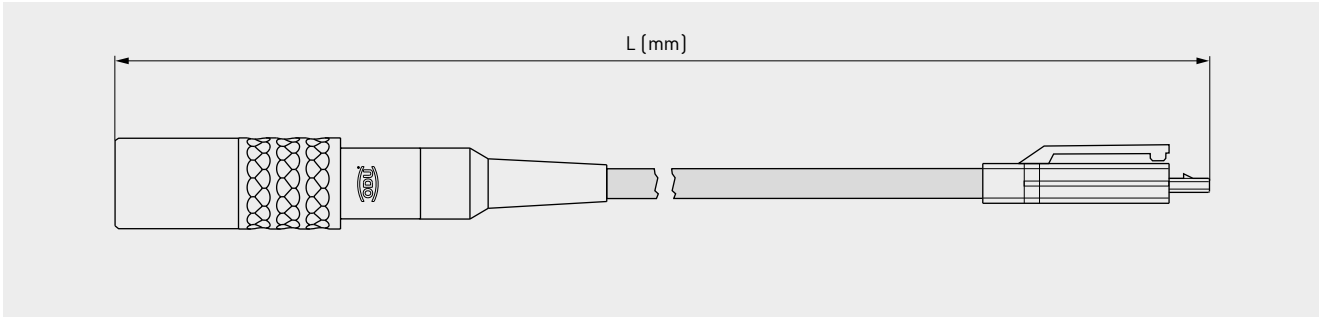

In configurations with ODU-Connectors on both ends the connector configured on Side A is always the same as Side B.

| Pos. 2-3 | Connector type |
|----------|--------------------|
| A2 | Break-away plug |
| S2 | Push-pull plug |
| K2 | In-line receptacle |

| Data rate* | Pin/Socket | 2 nd side | Pos. 12-13 |
|------------|------------|----------------------|------------|
| 1 Gbit/s | Pin | IEC 63171-2 | VA |
| 10 Gbit/s | | ODU | VB |
| 1 Gbit/s | Socket | IEC 63171-2 | V9 |

The available codings for the respective series can be found on page 14.

| Pos. 7 | Housing surface |
|--------|-----------------|
| C | Matte chrome |
| Z | Tin-nickel |

The available color of the bend and strain relief can be found on page 15.

| Pos. 14 -19 | Length |
|--|--------|
| Length L of assembly in mm (minimum cable length 300 mm) Example: 10000 mm = 001000 | |

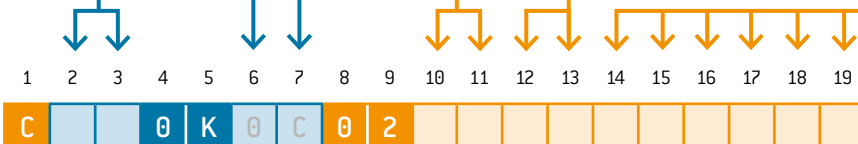

*Data rates mentioned are based on the respective standard data transmission protocol.

ODU-MAC® BLUE-LINE

SPE up to 5000 mm per single side assembly

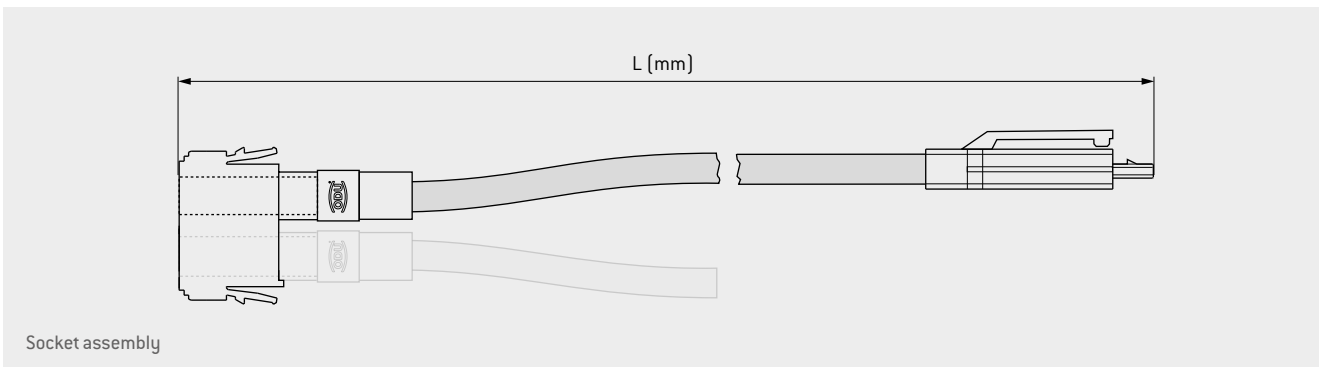
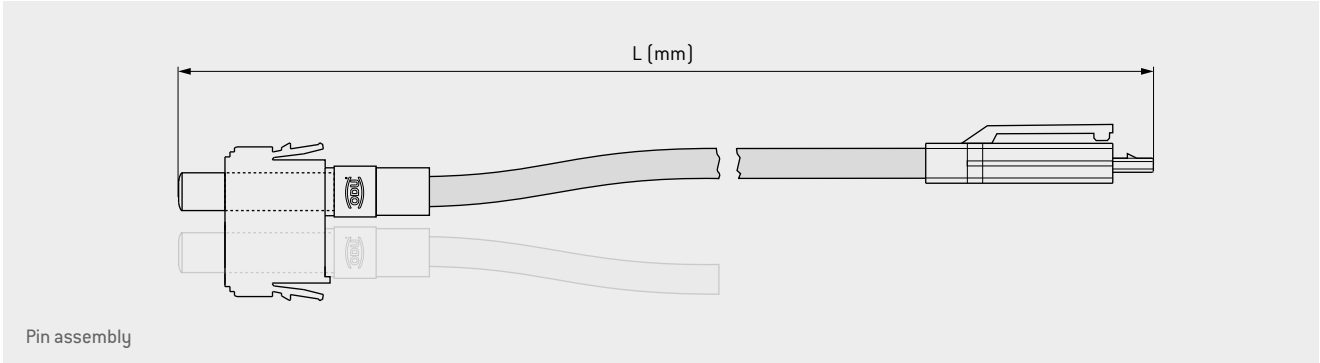

| Pos. 2 | Pin/Socket | Data rate* | Module units | Number of inserts | Pos. 8-9 |
|--------|------------|------------|--------------|-------------------|----------|
| P | Pin | 1 Gbit/s | 6 | 1 | 01 |
| S | Socket | 1 Gbit/s | 6 | 2 | 02 |

| Pos. 14-19 | Length |
|--|--------|
| Length L of assembly in mm (minimum cable length 300 mm) Example: 1000 mm = 001000 | |



*Data rates mentioned are based on the respective standard data transmission protocol.



DisplayPort® is a digital display interface that allows to transmit audio and video signals at the same time. It relies on packetized data transmission with an embedded clock signal making the data transfer more efficient and thereby supporting higher resolutions and refresh rates.

If the transmitter (graphics card) and receiver (display) are connected, they synchronize and set the signal levels between 200 and 600 mV. DisplayPort® does not specify the data line and image signal. Instead, each pixel is transferred sequentially. An image signal can therefore only be transmitted via a single channel. A total of four channels are available, connections via two channels are also possible. As with DVI and HDMI, each channel has its own pair of lines. An additional AUX channel not only houses the Display Data Channel (DDC) for the transmission of monitor data, but also offers enough bandwidth with almost 100 Mbit/s to supply webcams, microphones and loudspeakers in the monitor without additional cabling.

The maximum cable length for DisplayPort® is 5 meters.

High-speed data technology cable assemblies



DISPLAYPORT® UP TO 40 GBIT/S

| | |
|-------------------------------|-----------|
| ODU AMC® | <u>36</u> |
| ODU AMC® Series T | <u>37</u> |
| ODU MINI-SNAP® Series L | <u>38</u> |
| ODU MINI-SNAP® Series K | <u>40</u> |
| ODU-MAC® Blue-Line | <u>42</u> |

ODU AMC®

DisplayPort® up to 4800 mm per single side assembly

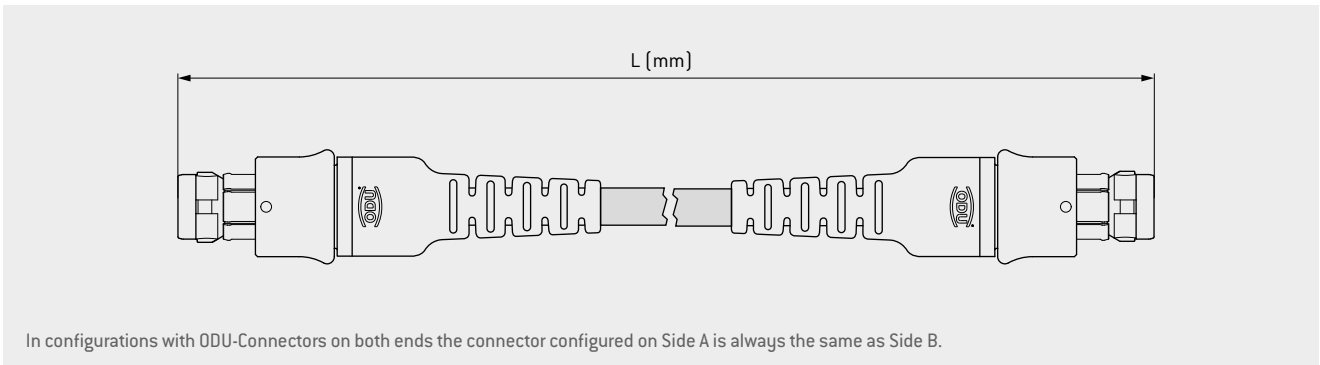
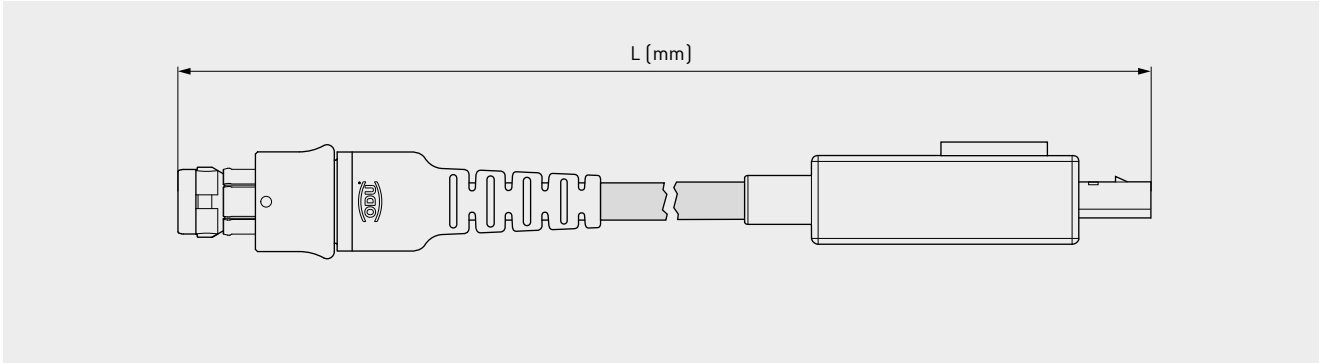

| Pos. 2-3 | Connector type |
|----------|------------------------|
| A1 | Break-away plug |
| S1 | Push-pull plug |
| K1 | In-line receptacle |
| G6 | Panel mount receptacle |

| Pos. 6 | Coding |
|--------|-------------|
| A | Light brown |
| B | Red |
| C | Blue |
| D | Green |

| Pin/Socket | Data rate* | 2 nd side | Pos. 12-13 |
|------------|-------------|----------------------|------------|
| Pin | 21.6 Gbit/s | DP-plug | YE |
| Socket | | ODU-Connector | YD |
| | | DP-plug | YF |

| Pos. 16-19 | Length |
|--|--------|
| Length L of assembly in mm (minimum cable length 300) Example: 1000 mm = 1000 | |



*Data rates mentioned are based on the respective standard data transmission protocol.



ODU AMC® SERIES T

DisplayPort® up to 4800 mm per single side assembly

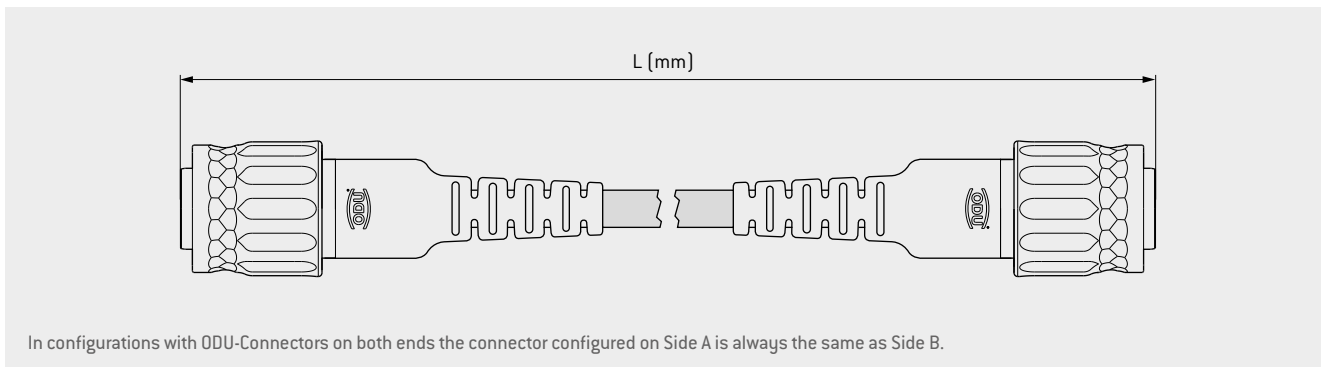
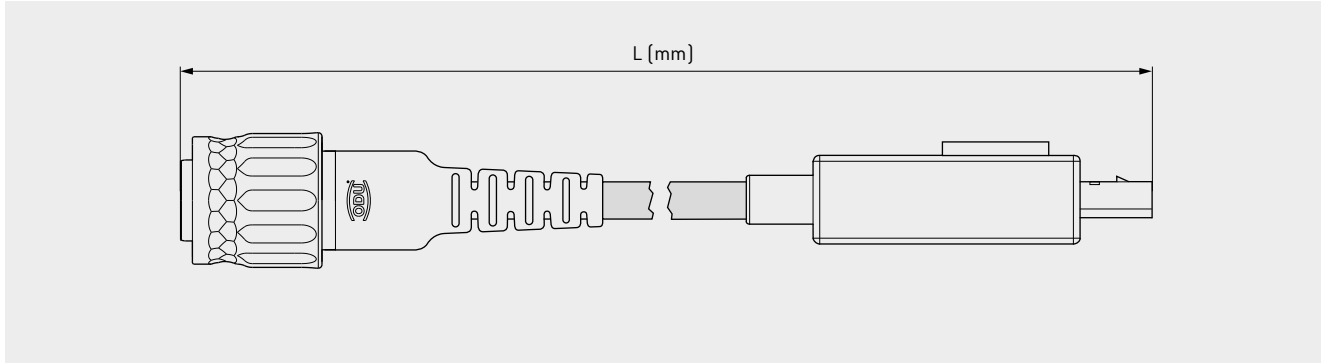

In configurations with ODU-Connectors on both ends the connector configured on Side A is always the same as Side B.

| Pos. 2-3 | Connector type |
|----------|------------------------|
| A1 | Break-away plug |
| S1 | Push-pull plug |
| C1 | Threaded plug |
| K1 | In-line receptacle |
| G6 | Panel mount receptacle |

| Pos. 6 | Coding |
|--------|-------------|
| A | Light brown |
| B | Red |
| C | Blue |
| D | Green |

| Pin/Socket | Data rate* | 2 nd side | Pos. 12-13 |
|------------|-------------|----------------------|------------|
| Pin | 21.6 Gbit/s | DP-plug | YE |
| Socket | | ODU-Connector | YD |
| | | DP-plug | YF |

| Pos. 16-19 | Length |
|------------|---|
| | Length L of assembly in mm (minimum cable length 300) Example: 1000 mm = 1000 |



*Data rates mentioned are based on the respective standard data transmission protocol.

ODU MINI-SNAP® SERIES L

DisplayPort® without bend relief up to 4800 mm per single side assembly

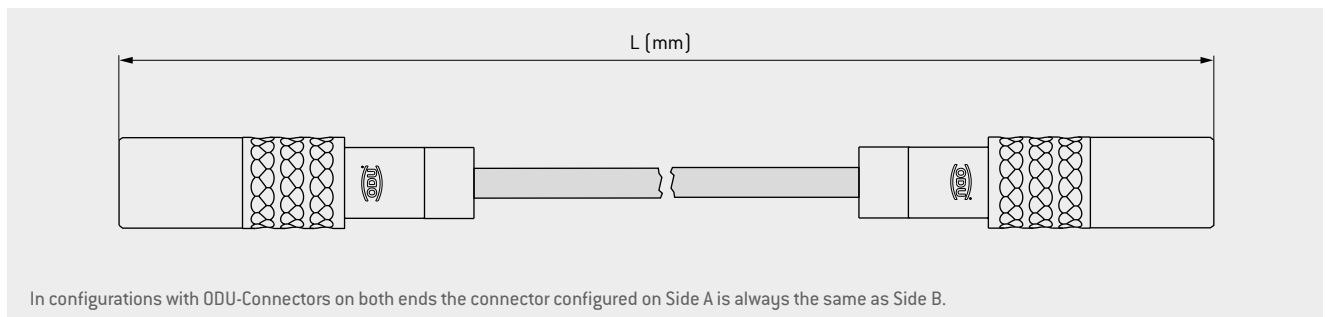
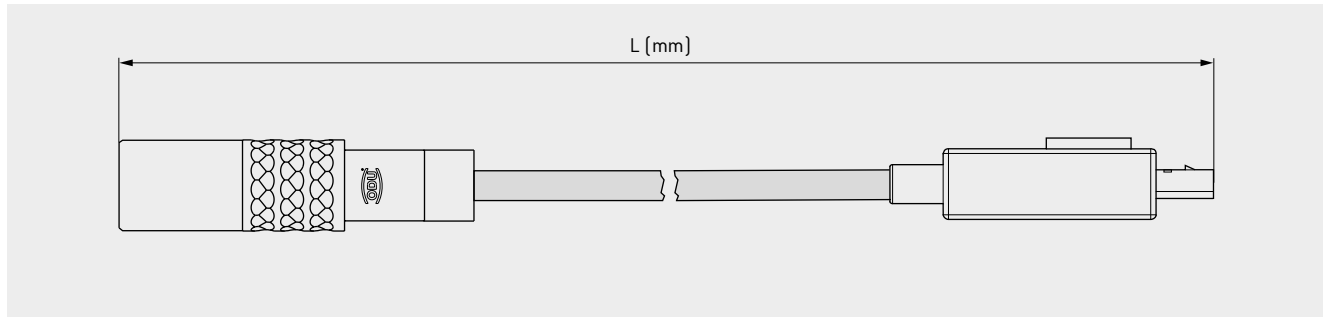

In configurations with ODU-Connectors on both ends the connector configured on Side A is always the same as Side B.

| Pos. 2-3 | Connector type |
|----------|------------------------|
| A1 | Break-away plug |
| S1 | Push-pull plug |
| K1 | In-line receptacle |
| G6 | Panel mount receptacle |

| Pin/Socket | Data rate* | 2 nd side | Pos. 12-13 |
|------------|------------|----------------------|------------|
| Pin | 40 Gbit/s | DP-plug | VE |
| | | ODU-Connector | VD |
| Socket | | DP-plug | VC |

The available codings for the respective series can be found on page 14.

| Pos. 7 | Housing surface |
|--------|-----------------|
| C | Matte chrome |
| Z | Tin-nickel |

| Pos. 16-19 | Length |
|--|--------|
| Length L of assembly in mm (minimum cable length 300 mm) Example: 1000 mm = 1000 | |



*Data rates mentioned are based on the respective standard data transmission protocol.

ODU MINI-SNAP® SERIES L

DisplayPort® with bend relief up to 4800 mm per single side assembly

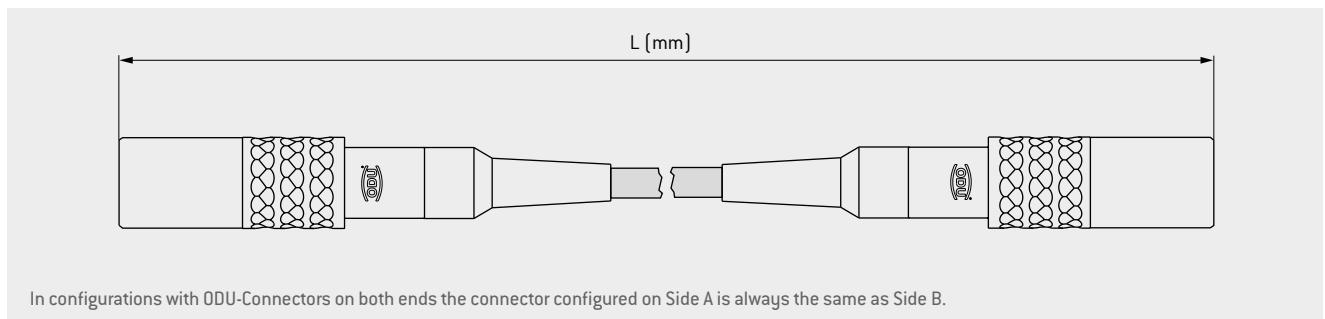
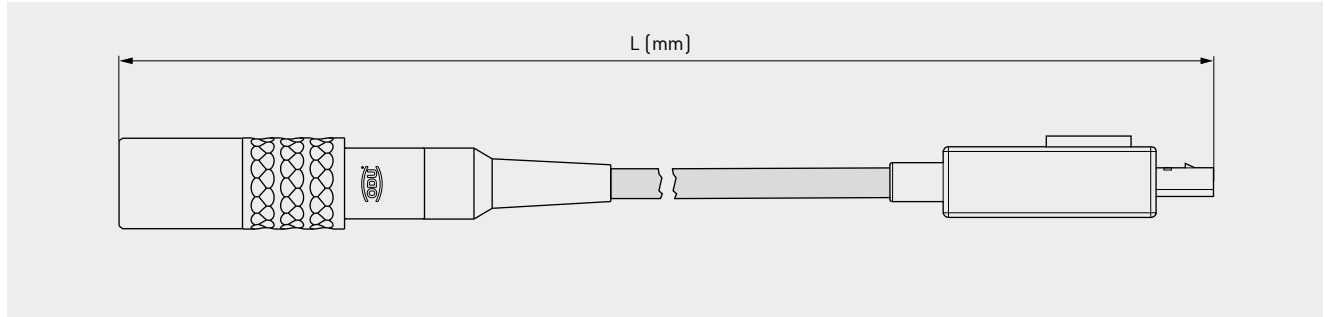

In configurations with ODU-Connectors on both ends the connector configured on Side A is always the same as Side B.

| Pos. 2-3 | Connector type |
|----------|--------------------|
| A2 | Break-away plug |
| S2 | Push-pull plug |
| K2 | In-line receptacle |

| Pin/Socket | Data rate* | 2 nd side | Pos. 12-13 |
|------------|------------|----------------------|------------|
| Pin | 40 Gbit/s | DP-plug | VE |
| | | ODU-Connector | VD |
| Socket | | DP-plug | VC |

The available codings for the respective series can be found on page 14.

| Pos. 7 | Housing surface |
|--------|-----------------|
| C | Matte chrome |
| Z | Tin-nickel |

The available color of the bend and strain relief can be found on page 15.

| Pos. 16-19 | Length |
|---|--------|
| Length L of assembly in mm (minimum cable length 300 mm) Example: 1000 mm = 1000 | |

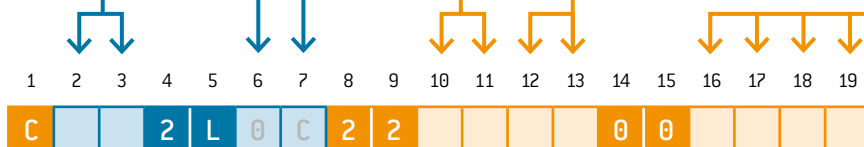

*Data rates mentioned are based on the respective standard data transmission protocol.

ODU MINI-SNAP® SERIES K

DisplayPort® without bend relief up to 4800 mm per single side assembly

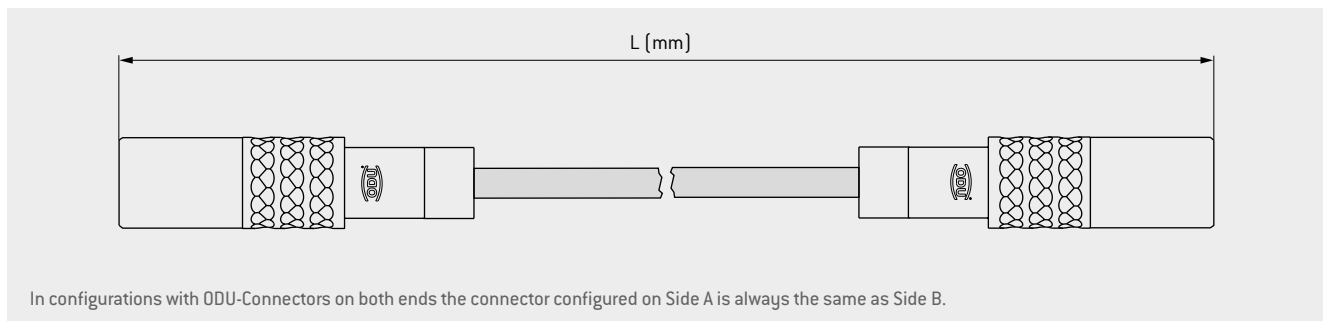
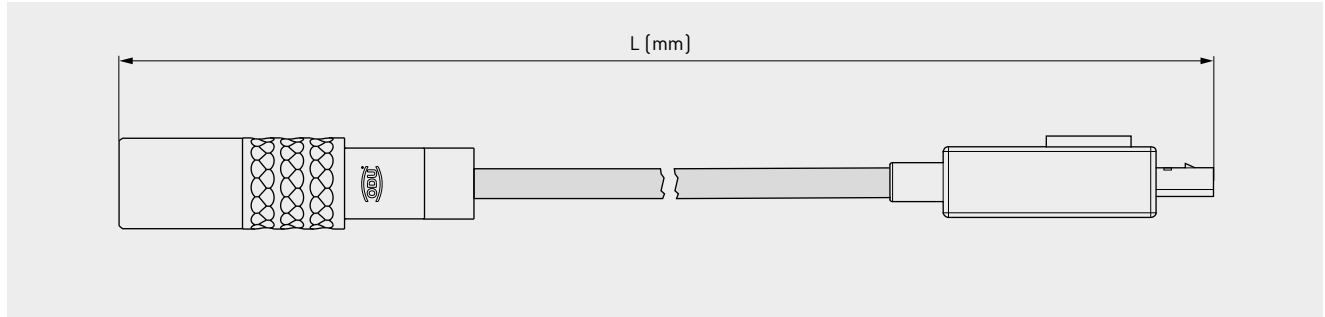

In configurations with ODU-Connectors on both ends the connector configured on Side A is always the same as Side B.

| Pos. 2-3 | Connector type |
|----------|------------------------|
| SA | Push-pull plug |
| KA | In-line receptacle |
| GB | Panel mount receptacle |

| Pin/Socket | Data rate* | 2 nd side | Pos. 12-13 |
|------------|------------|----------------------|------------|
| Pin | 40 Gbit/s | DP-plug | VE |
| | | ODU-Connector | VD |
| Socket | | DP-plug | VC |

The available codings for the respective series can be found on page 14.

| Pos. 7 | Housing surface |
|--------|-----------------|
| C | Matte chrome |
| Z | Tin-nickel |

| Pos. 16-19 | Length |
|--|--------|
| Length L of assembly in mm (minimum cable length 300 mm) Example: 1000 mm = 1000 | |



*Data rates mentioned are based on the respective standard data transmission protocol.

ODU MINI-SNAP® SERIES K

DisplayPort® with bend relief up to 4800 mm per single side assembly

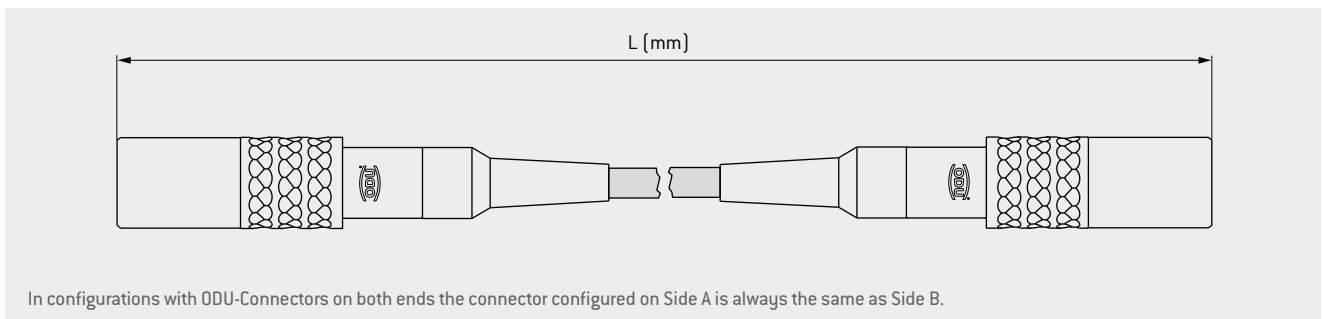
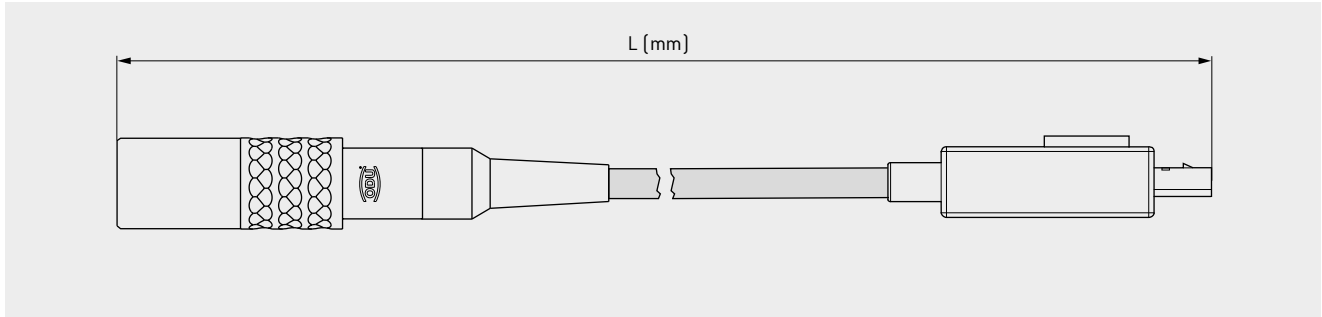

In configurations with ODU-Connectors on both ends the connector configured on Side A is always the same as Side B.

| Pos. 2-3 | Connector type |
|----------|--------------------|
| SB | Push-pull plug |
| KB | In-line receptacle |

| Pin/Socket | Data rate* | 2 nd side | Pos. 12-13 |
|------------|------------|----------------------|------------|
| Pin | 40 Gbit/s | DP-plug | VE |
| Socket | | ODU-Connector | VD |
| | | DP-plug | VC |

The available codings for the respective series can be found on page 14.

| Pos. 7 | Housing surface |
|--------|-----------------|
| C | Matte chrome |
| Z | Tin-nickel |

The available color of the bend and strain relief can be found on page 15.

| Pos. 16-19 | Length |
|---|--------|
| Length L of assembly in mm (minimum cable length 300 mm) Example: 1000 mm = 1000 | |

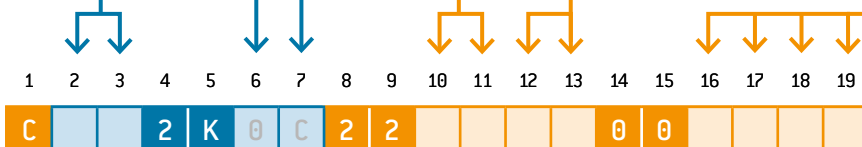

*Data rates mentioned are based on the respective standard data transmission protocol.

ODU-MAC® BLUE-LINE

DisplayPort® up to 4800 mm per single side assembly

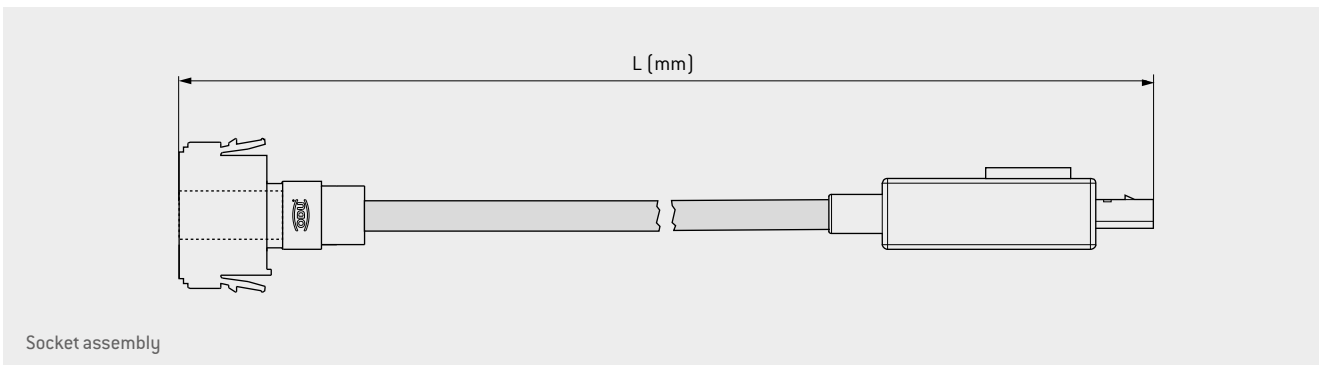
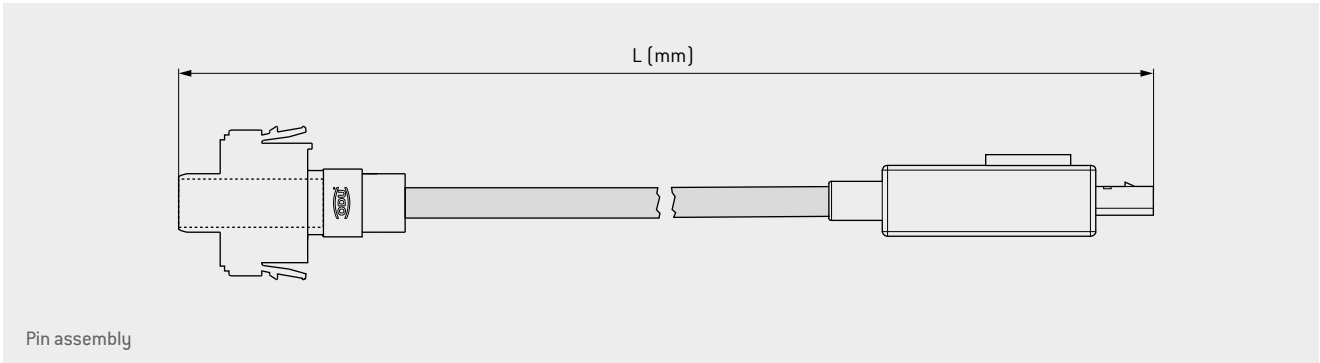

| Pos. 2 | Pin/Socket | Data rate* | Module units |
|--------|------------|------------|--------------|
| P | Pin | 40 Gbit/s | 7 |
| S | Socket | | |

| Pos. 16 -19 | Length |
|--|--------|
| Length L of assembly in mm (minimum cable length 300 mm) Example: 1000 mm = 1000 | |

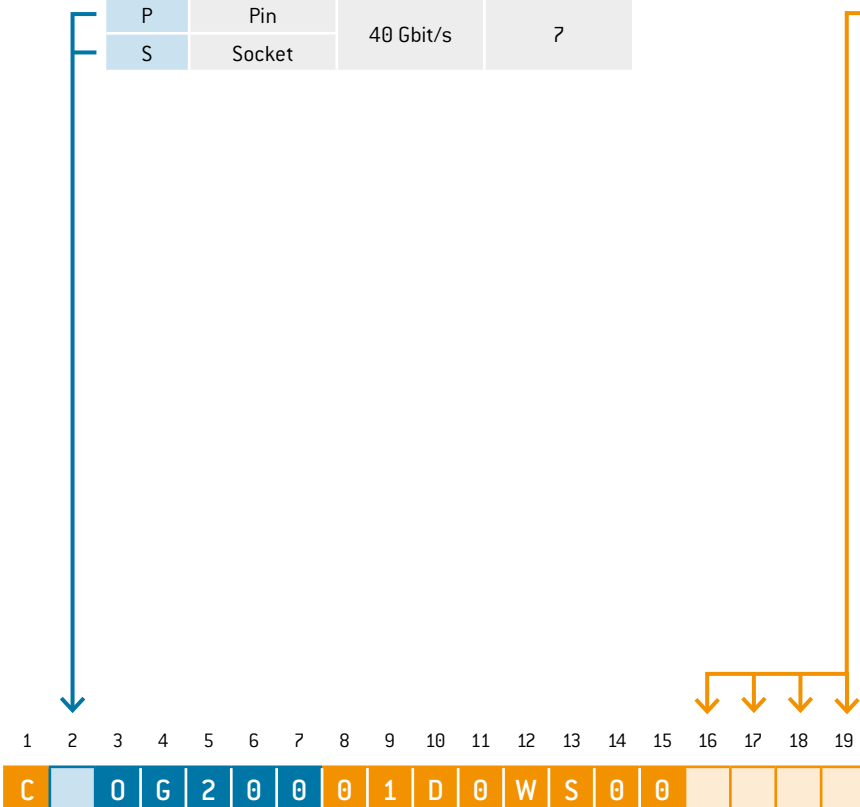

*Data rates mentioned are based on the respective standard data transmission protocol.



The abbreviation HDMI® stands for High-Definition Multimedia Interface. It refers to a digital multimedia interface that can deliver audio and video signals via a single cable – in contrast to analog predecessors such as VGA, DVI or SCART HDMI® is the go-to standard for digitally transmitting uncompressed video and audio data. The current standard HDMI® 2.1 supports up to 45 Gbit/s in bandwidth and a 8K resolution at 60 Hz.

The maximum cable length for HDMI® is 5 meters.

High-speed data technology cable assemblies

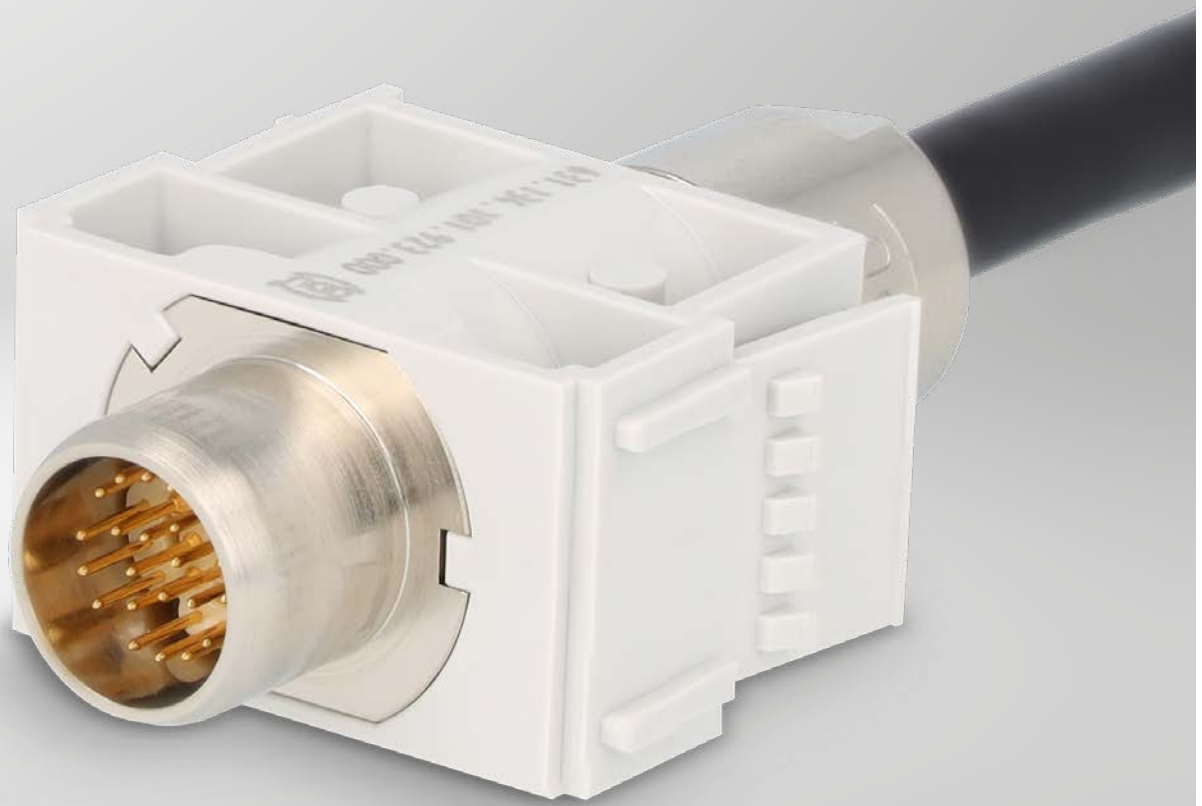

HDMI® UP TO 48 GBIT/S

| | |
|-------------------------------|--------------------|
| ODU AMC® | 46 |
| ODU AMC® Series T | 47 |
| ODU AMC® High-Density | 48 |
| ODU-MAC® Blue-Line | 49 |
| ODU MINI-SNAP® Series L | 50 |
| ODU MINI-SNAP® Series K | 52 |

ODU AMC®

HDMI® up to 3000 mm per single side assembly

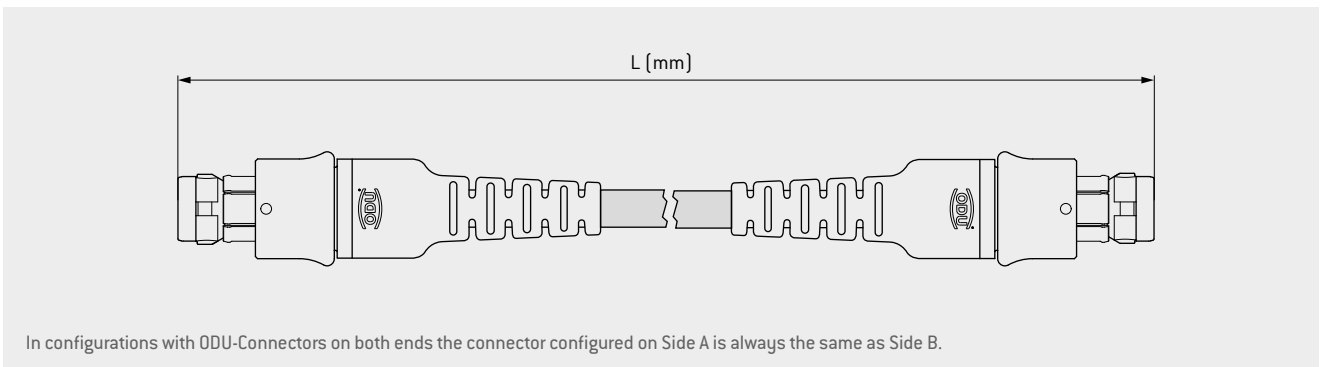
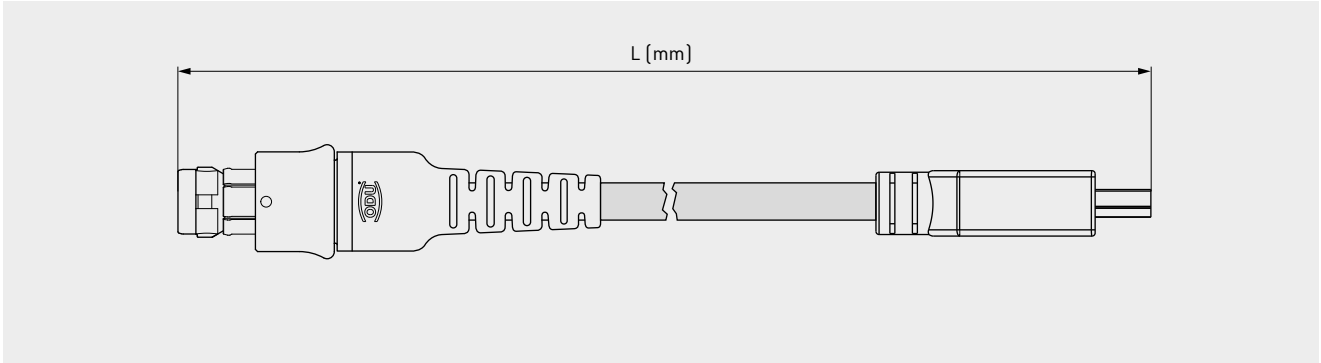

| Pos. 2-3 | Connector type |
|----------|------------------------|
| A1 | Break-away plug |
| S1 | Push-pull plug |
| K1 | In-line receptacle |
| G6 | Panel mount receptacle |

| Pos. 6 | Coding |
|--------|-------------|
| A | Light brown |
| B | Red |
| C | Blue |
| D | Green |

| Pin/Socket | Data rate* | 2 nd side | Pos. 12-13 |
|------------|-------------|----------------------|------------|
| Pin | 10.2 Gbit/s | HDMI® A Plug | YQ |
| | | ODU-Connector | YP |
| Socket | | HDMI® A Plug | YR |

| Pos. 16-19 | Length |
|---|--------|
| Length L of assembly in mm (minimum cable length 300) Example: 1000 mm = 1000 | |



*Data rates mentioned are based on the respective standard data transmission protocol.



ODU AMC® SERIES T

HDMI® up to 3000 mm per single side assembly

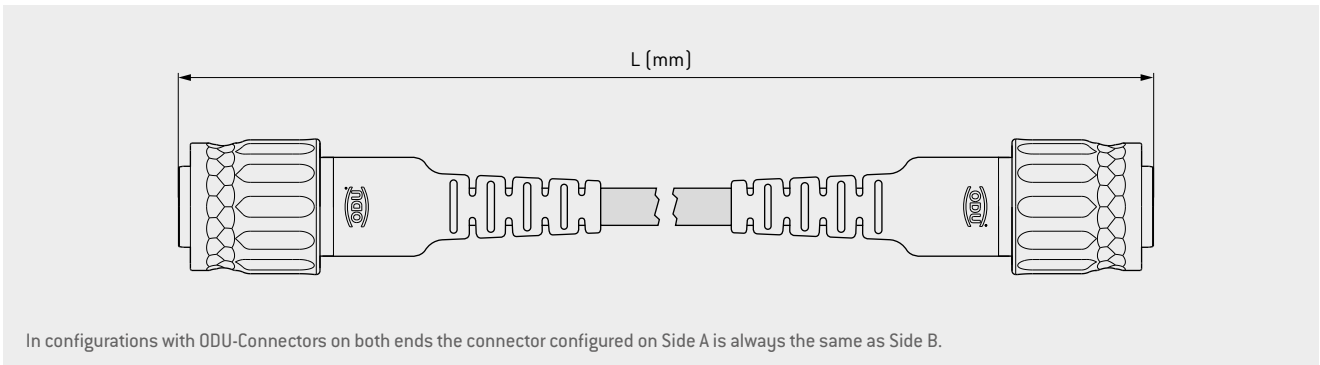
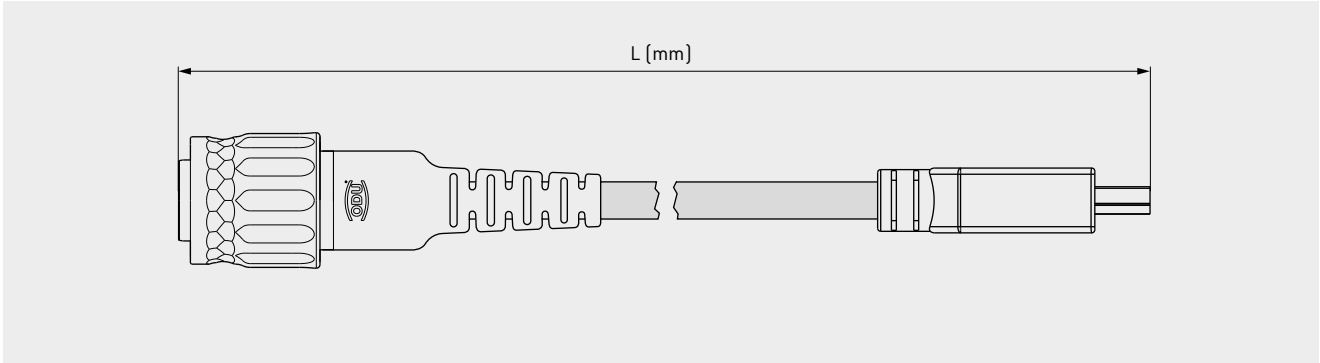

In configurations with ODU-Connectors on both ends the connector configured on Side A is always the same as Side B.

| Pos. 2-3 | Connector type |
|----------|------------------------|
| A1 | Break-away plug |
| S1 | Push-pull plug |
| C1 | Threaded plug |
| K1 | In-line receptacle |
| G6 | Panel mount receptacle |

| Pos. 6 | Coding |
|--------|-------------|
| A | Light brown |
| B | Red |
| C | Blue |
| D | Green |

| Pin/Socket | Data rate* | 2 nd side | Pos. 12-13 |
|------------|-------------|----------------------|------------|
| Pin | 10.2 Gbit/s | HDMI® A Plug | ZD |
| | | ODU-Connector | ZB |
| Socket | | HDMI® A Plug | ZC |

| Pos. 16-19 | Length |
|---|--------|
| Length L of assembly in mm (minimum cable length 300) Example: 1000 mm = 1000 | |



C E T T 2 0 4 I 0 0

*Data rates mentioned are based on the respective standard data transmission protocol.

ODU AMC® HIGH-DENSITY

HDMI® up to 3000 mm per single side assembly

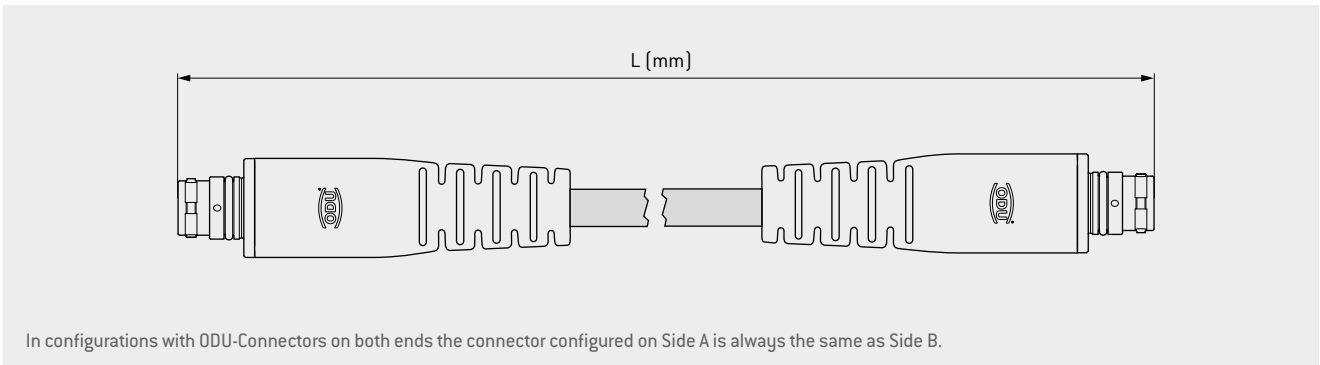
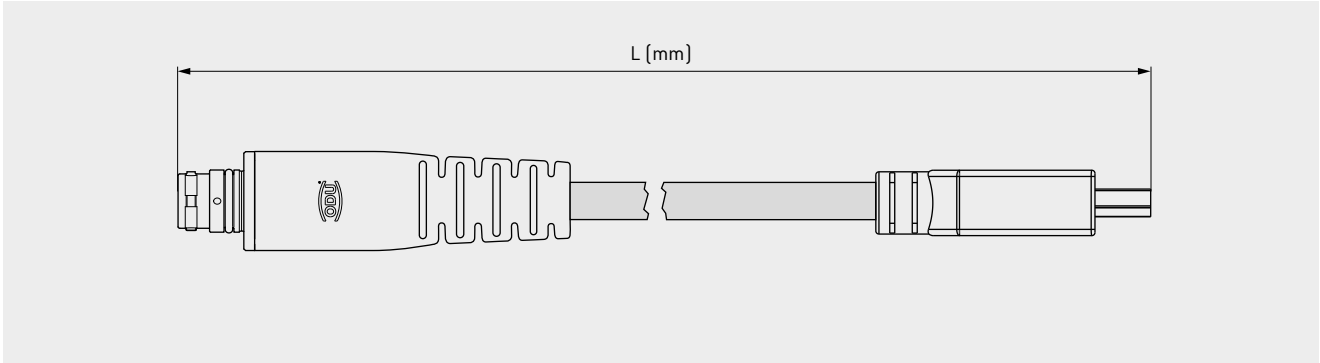

| Pos. 2-3 | Connector type |
|----------|--|
| A1 | Break-away plug |
| C1 | Threaded plug |
| K1 | In-line receptacle |
| G6 | Panel mount receptacle |
| KC | In-line receptacle with screw-lock |
| GS | Panel mount receptacle with screw-lock |

| Pos. 6 | Coding |
|--------|-------------|
| A | Light brown |
| B | Red |
| C | Blue |
| D | Green |

| Pin/Socket | Data rate* | 2 nd side | Pos. 12-13 |
|------------|-------------|----------------------|------------|
| Pin | 10.2 Gbit/s | HDMI® A Plug | YN |
| | | ODU-Connector | YM |
| Socket | | HDMI® A Plug | YO |

| Pos. 16-19 | Length |
|------------|---|
| | Length L of assembly in mm (minimum cable length 300) Example: 1000 mm = 1000 |



*Data rates mentioned are based on the respective standard data transmission protocol.

ODU-MAC® BLUE-LINE

HDMI® up to 3000 mm per single side assembly

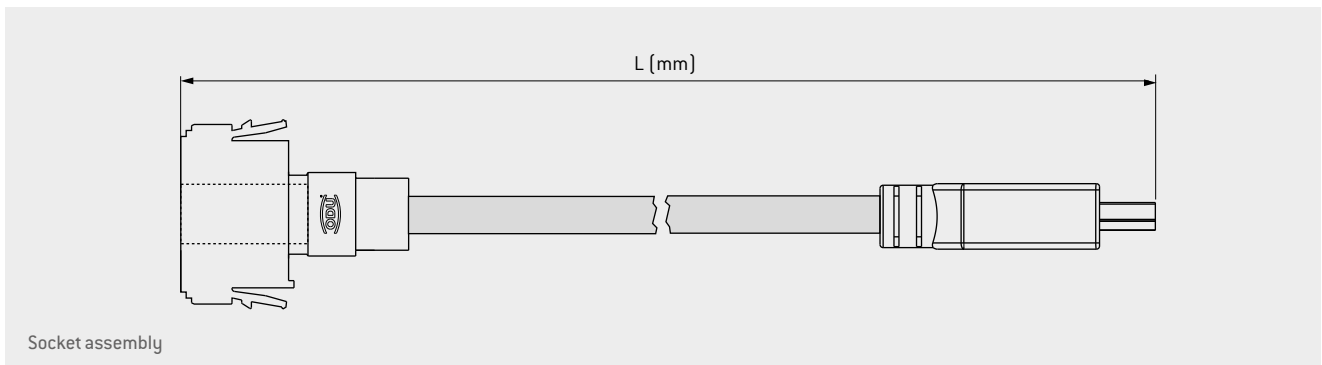
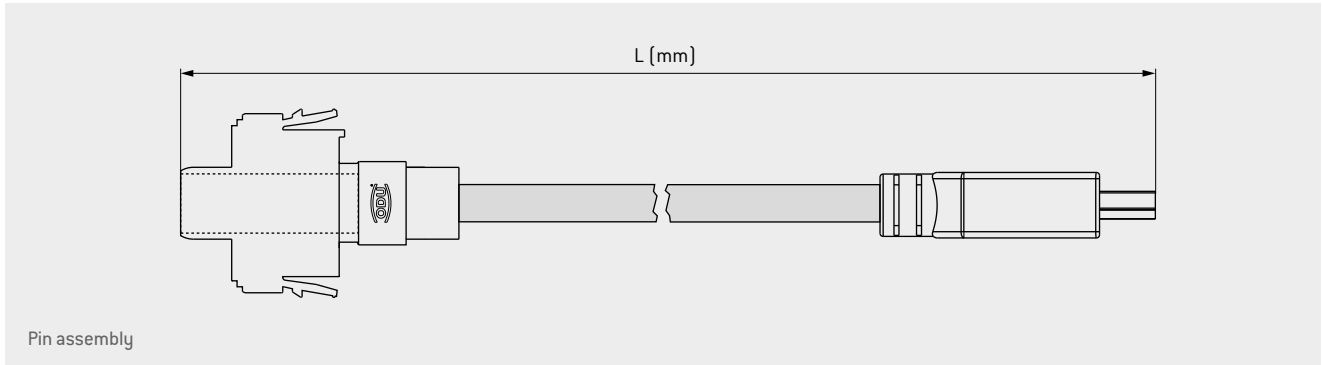

| Pos. 2 | Pin/Socket |
|--------|------------|
| P | Pin |
| S | Socket |

| Data rate* | Module units | 2 nd side | Pos. 12-13 |
|------------|--------------|----------------------|------------|
| 18 Gbit/s | ? | HDMI® A Plug | WU |
| 48 Gbit/s | | HDMI® A Plug | WT |

| Pos. 16-19 | Length |
|---|--------|
| Length L of assembly in mm (minimum cable length 300) Example: 1000 mm = 1000 | |

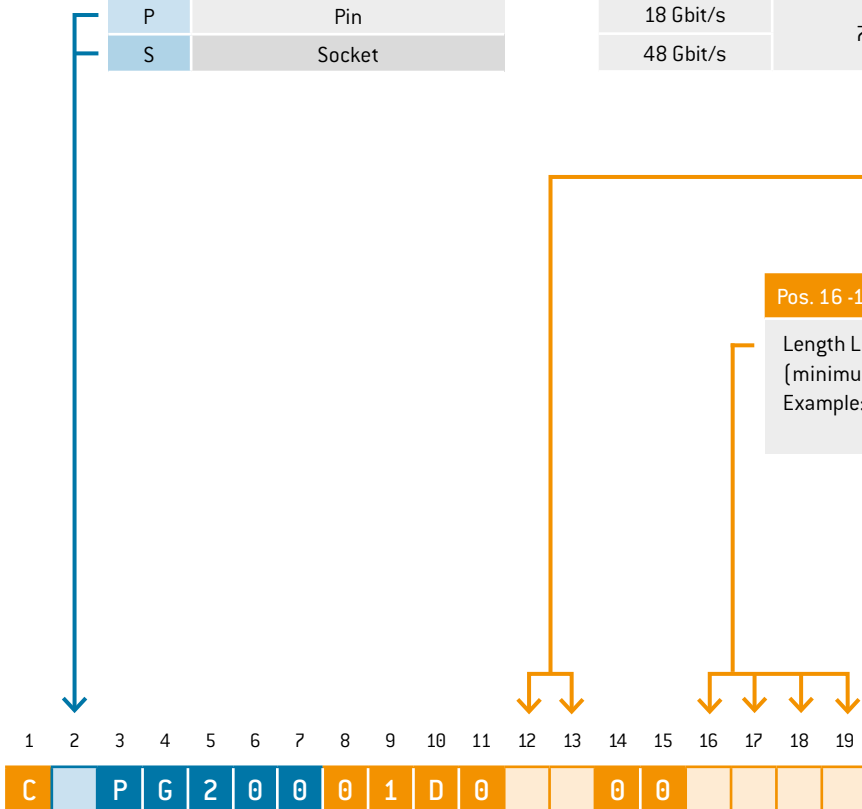

*Data rates mentioned are based on the respective standard data transmission protocol.

ODU MINI-SNAP® SERIES L

HDMI® without bend relief up to 3000 mm per single side assembly

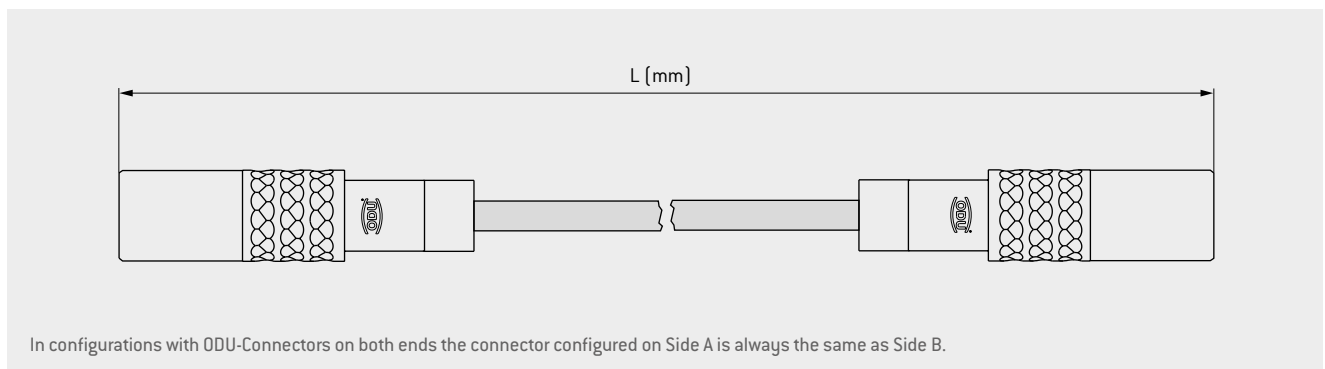
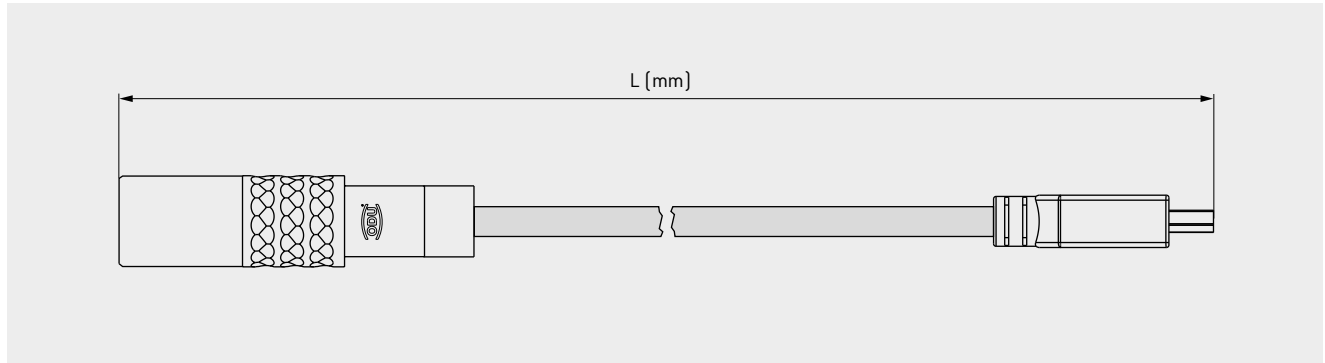

In configurations with ODU-Connectors on both ends the connector configured on Side A is always the same as Side B.

| Pos. 2-3 | Connector type |
|----------|------------------------|
| A1 | Break-away plug |
| S1 | Push-pull plug |
| K1 | In-line receptacle |
| G6 | Panel mount receptacle |

The available codings for the respective series can be found on page 14.

| Pos. 7 | Housing surface |
|--------|-----------------|
| C | Matte chrome |
| Z | Tin-nickel |

| Pos. 8-9 | Data rate* | Pin/Socket | 2 nd side | Pos. 12-13 |
|----------|------------|------------|----------------------|------------|
| 16 | 18 Gbit/s | Pin | HDMI® A Plug | VJ |
| | | Socket | ODU-Connector | VK |
| 22 | 48 Gbit/s | Pin | HDMI® A Plug | VH |
| | | | ODU-Connector | VG |
| | | Socket | HDMI® A Plug | VF |

| Pos. 16-19 | Length |
|--|--------|
| Length L of assembly in mm (minimum cable length 300 mm) Example: 1000 mm = 1000 | |

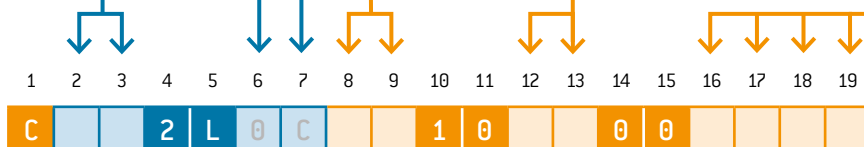

C 2 L 0 C 1 0 0 0

*Data rates mentioned are based on the respective standard data transmission protocol and are determined by the number of conductors of the ODU connector.

ODU MINI-SNAP® SERIES L

HDMI® with bend relief up to 3000 mm per single side assembly

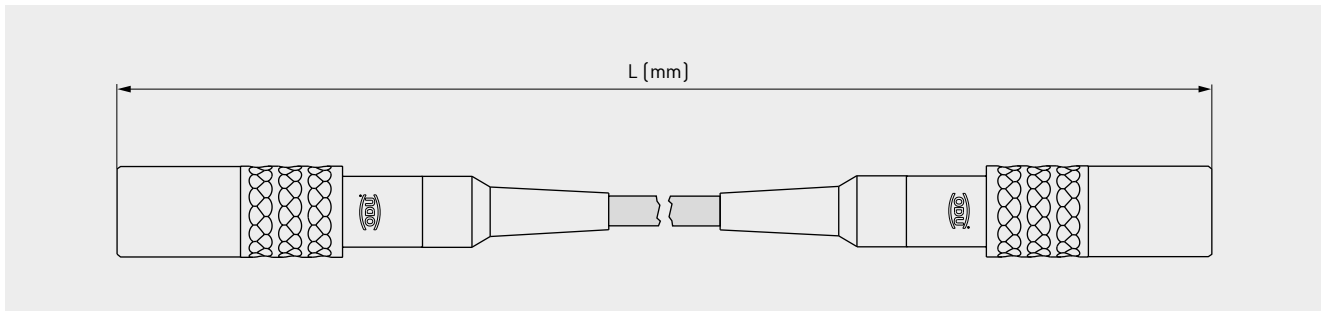
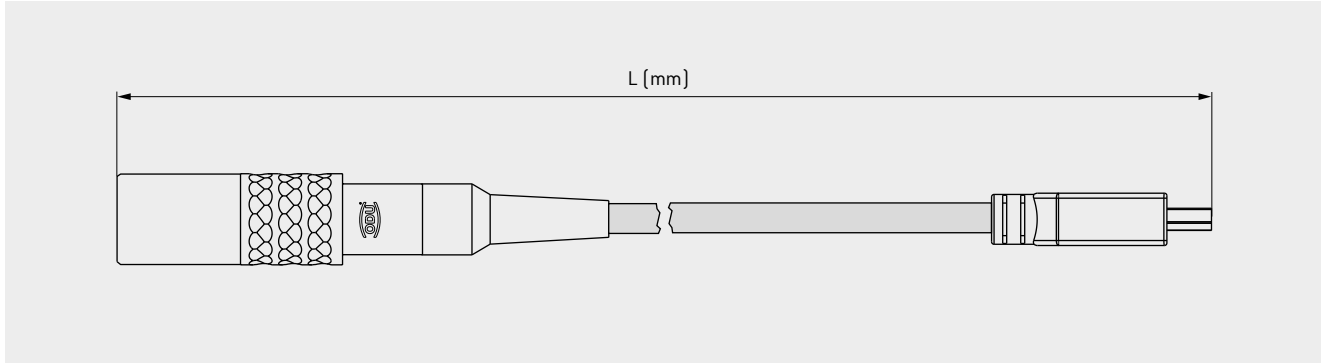

In configurations with ODU-Connectors on both ends the connector configured on Side A is always the same as Side B.

| Pos. 2-3 | Connector type |
|----------|--------------------|
| A2 | Break-away plug |
| S2 | Push-pull plug |
| K2 | In-line receptacle |

The available codings for the respective series can be found on page 14.

| Pos. 7 | Housing surface |
|--------|-----------------|
| C | Matte chrome |
| Z | Tin-nickel |

The available color of the bend and strain relief can be found on page 15.

| Pos. 8-9 | Data rate* | Pin/Socket | 2 nd side | Pos. 12-13 |
|----------|------------|------------|----------------------|------------|
| 16 | 18 Gbit/s | Pin | HDMI® A Plug | VJ |
| | | Socket | ODU-Connector | VK |
| 22 | 48 Gbit/s | Pin | HDMI® A Plug | VH |
| | | | ODU-Connector | VG |
| | | Socket | HDMI® A Plug | VF |

| Pos. 16-19 | Length |
|---|--------|
| Length L of assembly in mm (minimum cable length 300 mm) Example: 1000 mm = 1000 | |

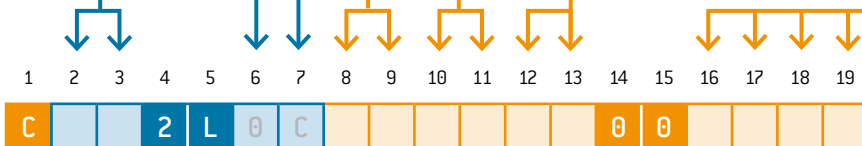

*Data rates mentioned are based on the respective standard data transmission protocol and are determined by the number of conductors of the ODU connector.

ODU MINI-SNAP® SERIES K

HDMI® without bend relief up to 3000 mm per single side assembly

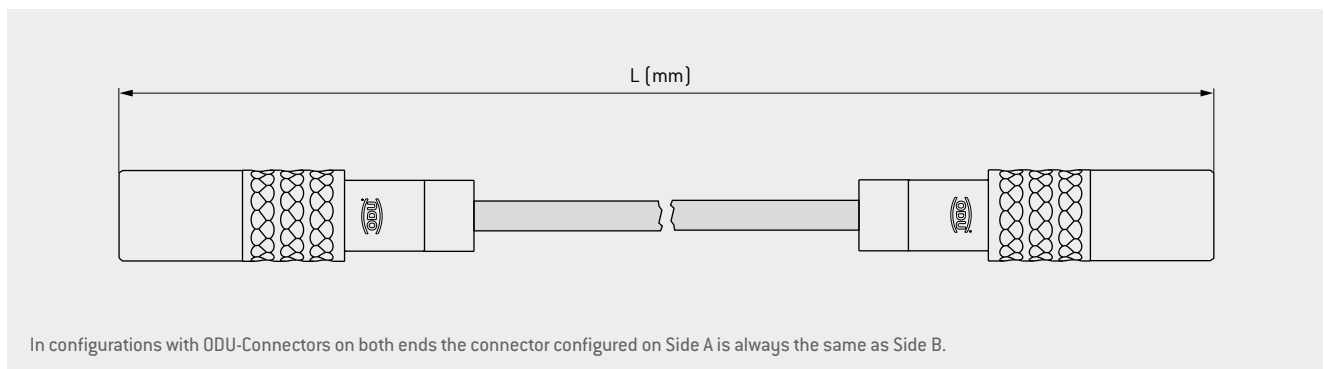
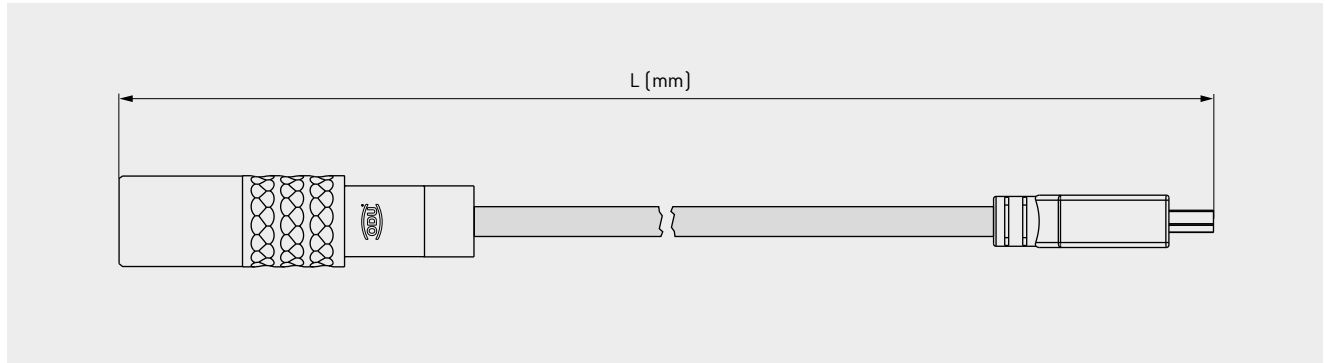

In configurations with ODU-Connectors on both ends the connector configured on Side A is always the same as Side B.

| Pos. 2-3 | Connector type |
|----------|------------------------|
| SA | Push-pull plug |
| KA | In-line receptacle |
| GB | Panel mount receptacle |

The available codings for the respective series can be found on page 14.

| Pos. 7 | Housing surface |
|--------|-----------------|
| C | Matte chrome |
| Z | Tin-nickel |

| Pos. 8-9 | Data rate* | Pin/Socket | 2 nd side | Pos. 12-13 |
|----------|------------|------------|----------------------|------------|
| 16 | 18 Gbit/s | Pin | HDMI® A Plug | VJ |
| | | Socket | ODU-Connector | VK |
| 22 | 48 Gbit/s | Pin | HDMI® A Plug | VH |
| | | | ODU-Connector | VG |
| | | Socket | HDMI® A Plug | VF |

| Pos. 16-19 | Length |
|--|--------|
| Length L of assembly in mm (minimum cable length 300 mm) Example: 1000 mm = 1000 | |

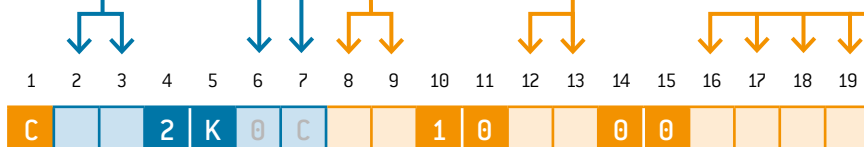

*Data rates mentioned are based on the respective standard data transmission protocol and are determined by the number of conductors of the ODU connector.

ODU MINI-SNAP® SERIES K

HDMI® with bend relief up to 3000 mm per single side assembly

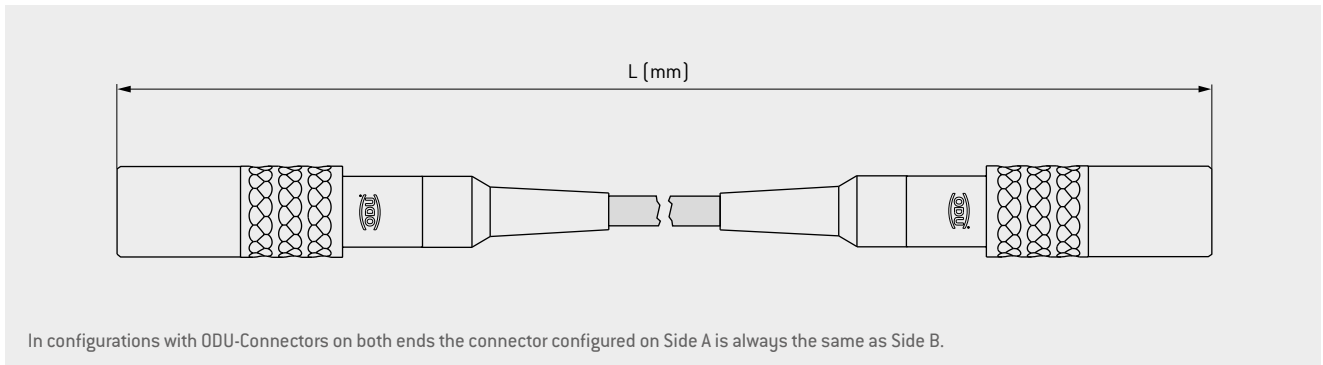
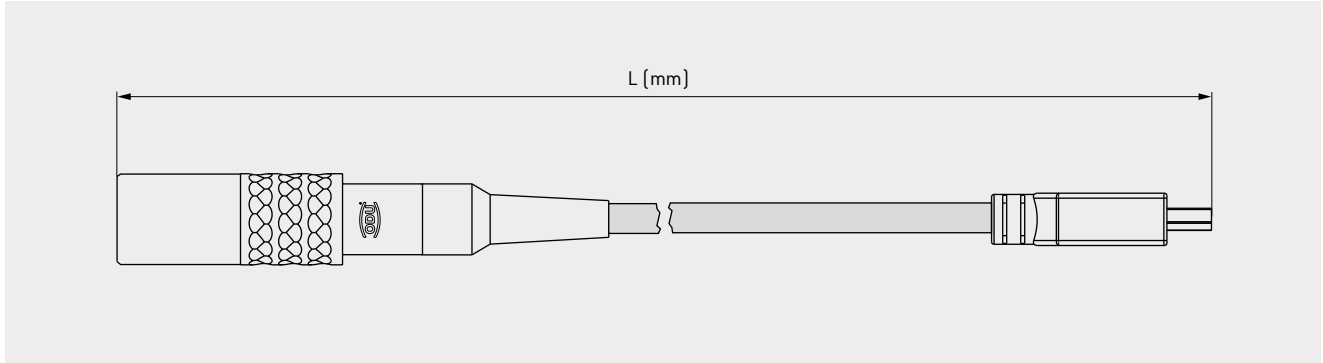

In configurations with ODU-Connectors on both ends the connector configured on Side A is always the same as Side B.

| Pos. 2-3 | Connector type |
|----------|--------------------|
| SB | Push-pull plug |
| KB | In-line receptacle |

The available codings for the respective series can be found on page 14.

| Pos. 7 | Housing surface |
|--------|-----------------|
| C | Matte chrome |
| Z | Tin-nickel |

The available color of the bend and strain relief can be found on page 15.

| Pos. 8-9 | Data rate* | Pin/Socket | 2 nd side | Pos. 12-13 |
|----------|------------|------------|----------------------|------------|
| 16 | 18 Gbit/s | Pin | HDMI® A Plug | VJ |
| | | Socket | ODU-Connector | VK |
| 22 | 48 Gbit/s | Pin | HDMI® A Plug | VH |
| | | | ODU-Connector | VG |
| | | Socket | HDMI® A Plug | VF |

| Pos. 16-19 | Length |
|---|--------|
| Length L of assembly in mm (minimum cable length 300 mm) Example: 1000 mm = 1000 | |

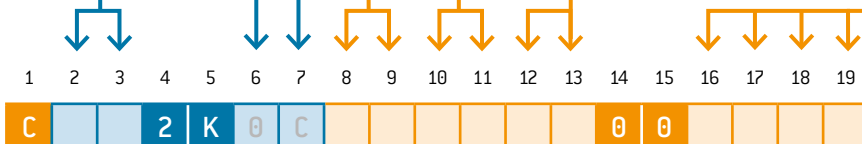

*Data rates mentioned are based on the respective standard data transmission protocol and are determined by the number of conductors of the ODU connector.



USB® transmits the data bit-serially, i.e. the individual bits are transmitted one after the other. The transmission takes place differentially via a symmetrical pair of wires: if the high level is on the first wire, the low level is on the second and vice versa. The signal receiver evaluates the differential voltage at a termination resistor. From their sign, the two logical states zero or one result. The differential method and the use of twisted wires largely eliminate electrically irradiated interference.

Compared to previous solutions, USB® offers significantly higher data transfer rates. However, the data is transferred in packages. For some time-critical applications, it is therefore less suitable, such as packages with only a few bytes that reduce the transfer rate, or when collecting bytes to fill a package would delay transmission.

The maximum channel length for USB® 2.0 is 4 meters, while for USB® 3.2 Gen 1 xX, it is limited to 2 meters.

High-speed data technology cable assemblies



USB® UP TO 10 GBIT/S

| | |
|-------------------------------|----|
| ODU AMC® | 56 |
| ODU AMC® High-Density | 57 |
| ODU MINI-SNAP® Series L | 58 |
| ODU MINI-SNAP® Series K | 62 |
| ODU-MAC® Blue-Line | 66 |

ODU AMC®

USB® up to 3000 mm per single side assembly with transfer of 480 Mbit/s

USB® up to 2000 mm per single side assembly with transfer of 5 Gbit/s

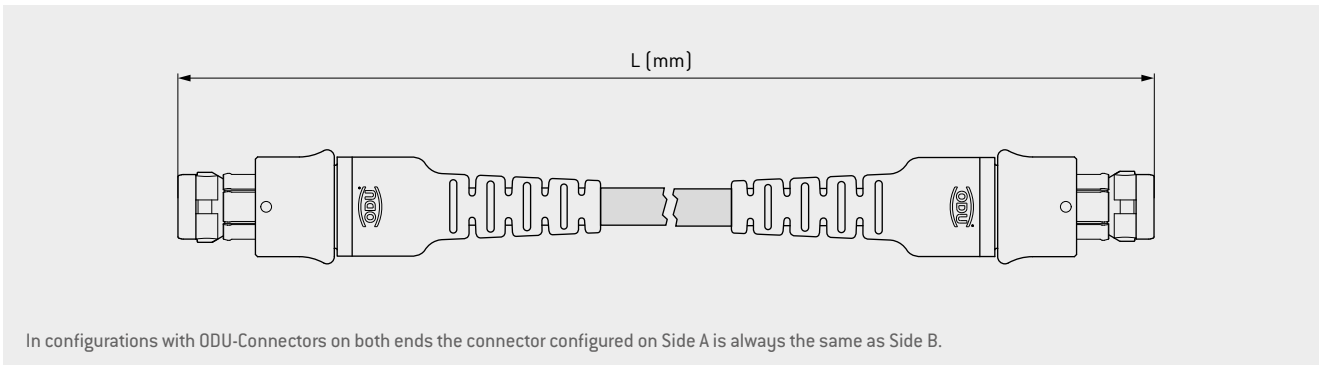
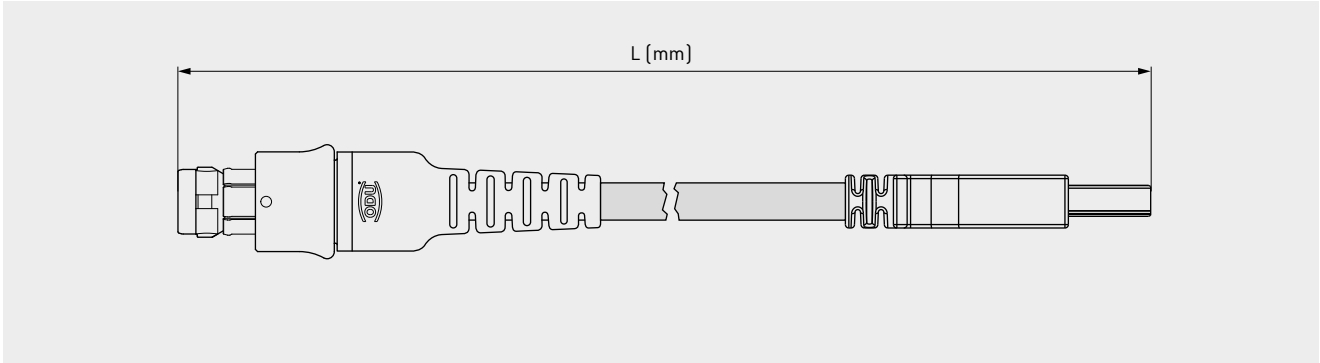

| Pos. 2-3 | Connector type |
|----------|------------------------|
| A1 | Break-away plug |
| S1 | Push-pull plug |
| K1 | In-line receptacle |
| G6 | Panel mount receptacle |

| Pos. 6 | Coding |
|--------|-------------|
| A | Light brown |
| B | Red |
| C | Blue |
| D | Green |

| Pos. 8-9 | Data rate* | Pin/Socket | 2 nd side | Pos. 12-13 |
|----------|------------|------------|----------------------|------------|
| 04 | 480 Mbit/s | Pin | USB® A Plug | YY |
| | | Socket | ODU-Connector | YX |
| 10 | 5 Gbit/s | Pin | USB® A Plug | YU |
| | | | ODU-Connector | YS |
| | | Socket | USB® A Plug | YV |

| Pos. 16-19 | Length |
|--|--------|
| Length L of assembly in mm (minimum cable length 300 mm) Example: 1000 mm = 1000 | |

| | | | | | | | | | | | | | | | | | | |
|---|---|---|---|---|---|---|---|---|----|----|----|----|----|----|----|----|----|----|
| 1 | 2 | 3 | 4 | 5 | 6 | 7 | 8 | 9 | 10 | 11 | 12 | 13 | 14 | 15 | 16 | 17 | 18 | 19 |
| C | | | O | Y | | R | | | 4 | I | | | 0 | 0 | | | | |

*Data rates mentioned are based on the respective standard data transmission protocol and are determined by the number of conductors of the ODU connector.

ODU AMC® HIGH-DENSITY

USB® up to 3000 mm per single side assembly with transfer of 480 Mbit/s

USB® up to 2000 mm per single side assembly with transfer of 5 Gbit/s

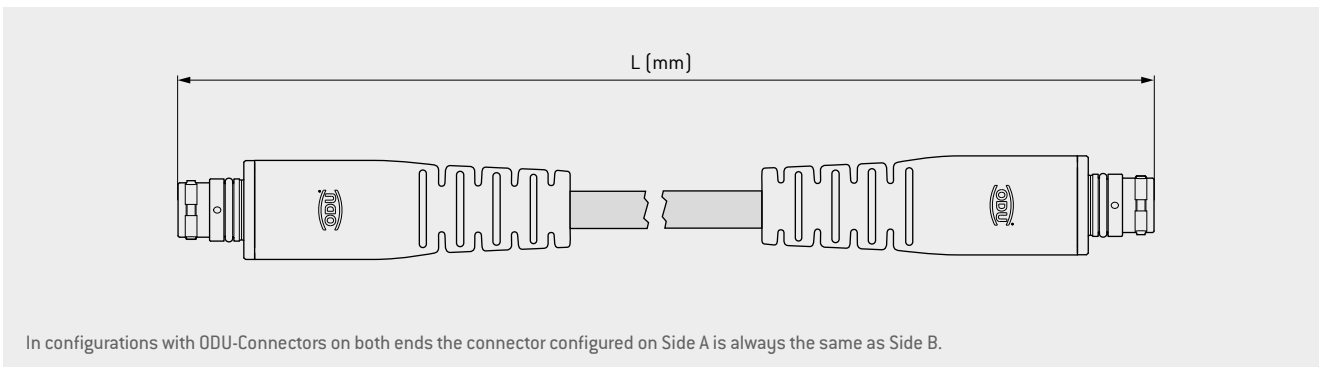
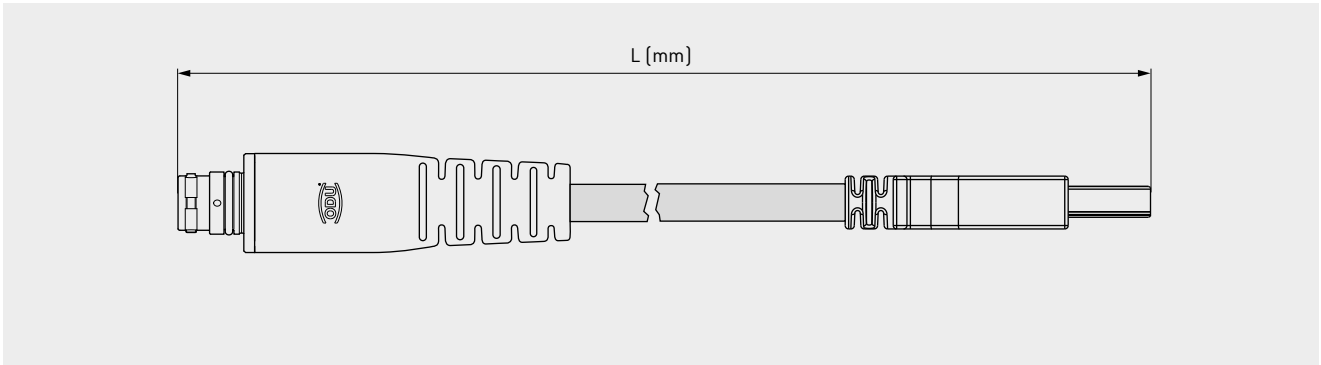

| Pos. 2-3 | Connector type | Pos. 4 | Size | Pos. 8-9 | Data rate* | Pin/Socket | 2 nd side | Pos. 12-13 |
|----------|--|--------|------|----------|------------|---------------|----------------------|------------|
| A1 | Break-away plug | C | 00 | 04 | 480 Mbit/s | Pin | USB® A Plug | YY |
| C1 | Threaded plug | | | | | | ODU-Connector | YX |
| K1 | In-line receptacle | 0 | 0 | 12 | 5 Gbit/s | Socket | USB® A Plug | YZ |
| G6 | Panel mount receptacle | | | | | | USB® A Plug | YU |
| KC | In-line receptacle with screw-lock | | | | | ODU-Connector | YS | |
| GS | Panel mount receptacle with screw-lock | | | | | | USB® A Plug | YV |

| Pos. 6 | Coding |
|--------|-------------|
| A | Light brown |
| B | Red |
| C | Blue |
| D | Green |

| Pos. 16-19 | Length |
|--|--------|
| Length L of assembly in mm (minimum cable length 300 mm) Example: 1000 mm = 1000 | |

| | | | | | | | | | | | | | | | | | | |
|---|---|---|---|---|---|---|---|---|----|----|----|----|----|----|----|----|----|----|
| 1 | 2 | 3 | 4 | 5 | 6 | 7 | 8 | 9 | 10 | 11 | 12 | 13 | 14 | 15 | 16 | 17 | 18 | 19 |
| C | | | W | | M | | | 4 | I | | | 0 | 0 | | | | | |

*Data rates mentioned are based on the respective standard data transmission protocol and are determined by the number of conductors of the ODU connector.

ODU MINI-SNAP® SERIES L

USB® without bend relief up to 3000 mm per single side assembly with transfer of 480 Mbit/s

USB® without bend relief up to 2000 mm per single side assembly with transfer of 5 Gbit/s

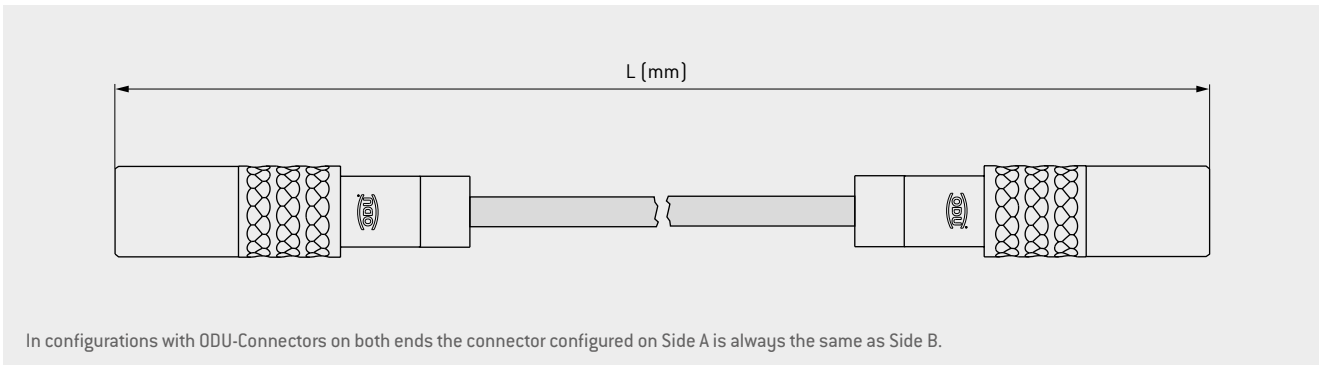
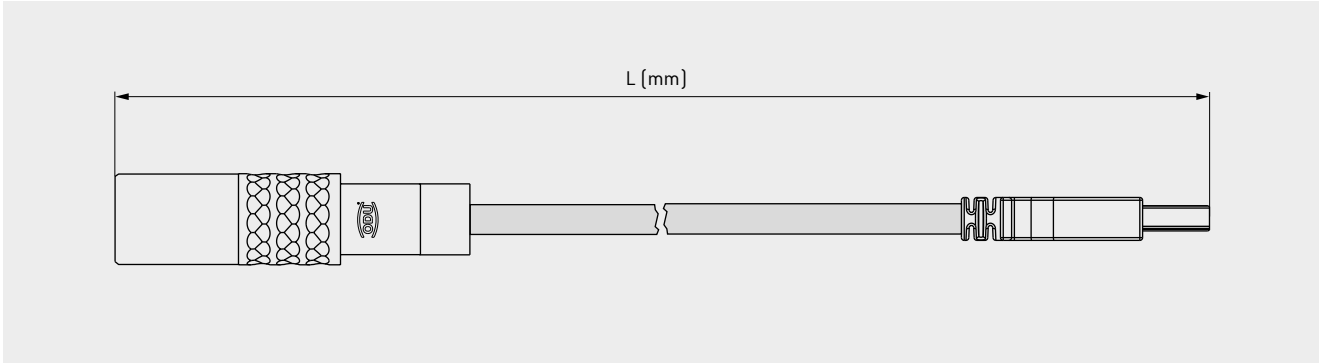

In configurations with ODU-Connectors on both ends the connector configured on Side A is always the same as Side B.

| Pos. 2-3 | Connector type |
|----------|--------------------------------|
| A1 | Break-away plug, 4 pin |
| S1 | Push-pull plug, 4 pin |
| K1 | In-line receptacle, 4 pin |
| G6 | Panel mount receptacle, 4 pin |
| A9 | Break-away plug, 10 pin |
| S9 | Push-pull plug, 10 pin |
| K9 | In-line receptacle, 10 pin |
| G9 | Panel mount receptacle, 10 pin |

The available codings for the respective series can be found on page 14.

| Pos. 7 | Housing surface |
|--------|-----------------|
| C | Matte chrome |
| Z | Tin-nickel |

| Pos. 8-9 | Data rate* | Pin/Socket | 2 nd side | Pos. 12-13 |
|----------|------------|------------|----------------------|------------|
| 04 | 480 Mbit/s | Pin | USB® A Plug | VS |
| | | Socket | ODU-Connector | VT |
| 10 | 5 Gbit/s | Pin | USB® A Plug | VP |
| | | Socket | ODU-Connector | VQ |
| | | | USB® A Plug | V0 |

| Pos. 16-19 | Length |
|---|--------|
| Length L of assembly in mm (minimum cable length 300 mm) Example: 1000 mm = 1000 | |

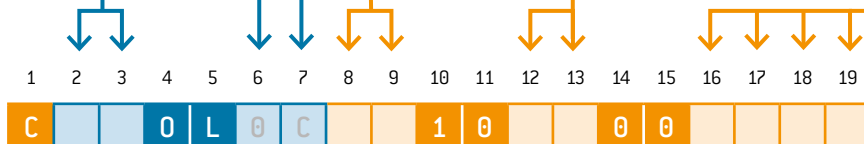

*Data rates mentioned are based on the respective standard data transmission protocol and are determined by the number of conductors of the ODU connector.

ODU MINI-SNAP® SERIES L

USB® with bend relief up to 3000 mm per single side assembly with transfer of 480 Mbit/s

USB® with bend relief up to 2000 mm per single side assembly with transfer of 5 Gbit/s

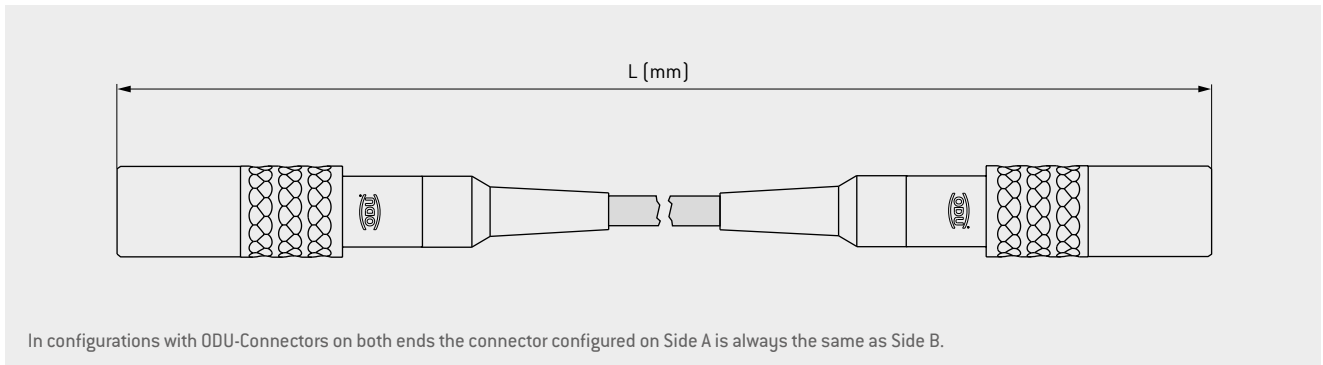
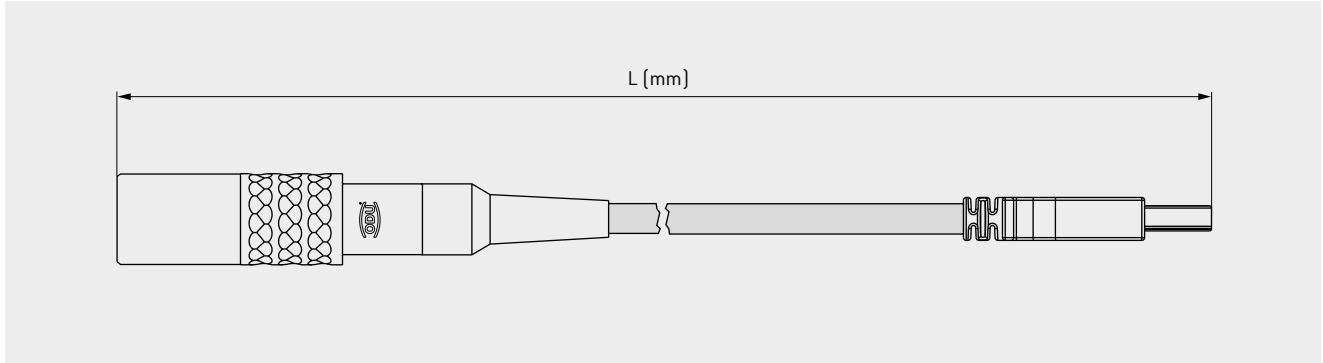

In configurations with ODU-Connectors on both ends the connector configured on Side A is always the same as Side B.

| Pos. 2-3 | Connector type |
|----------|----------------------------|
| A2 | Break-away plug, 4 pin |
| S2 | Push-pull plug, 4 pin |
| K2 | In-line receptacle, 4 pin |
| A9 | Break-away plug, 10 pin |
| S9 | Push-pull plug, 10 pin |
| K9 | In-line receptacle, 10 pin |

| Pos. 8-9 | Data rate* | Pin/Socket | 2 nd side | Pos. 12-13 |
|----------|------------|------------|----------------------|------------|
| 04 | 480 Mbit/s | Pin | USB® A Plug | VS |
| | | Socket | ODU-Connector | VT |
| 10 | 5 Gbit/s | Pin | USB® A Plug | VP |
| | | | ODU-Connector | VQ |
| | | Socket | USB® A Plug | V0 |

The available codings for the respective series can be found on page 14.

| Pos. 7 | Housing surface |
|--------|-----------------|
| C | Matte chrome |
| Z | Tin-nickel |

The available color of the bend and strain relief can be found on page 15.

| Pos. 16-19 | Length |
|---|--------|
| Length L of assembly in mm (minimum cable length 300 mm) Example: 1000 mm = 1000 | |

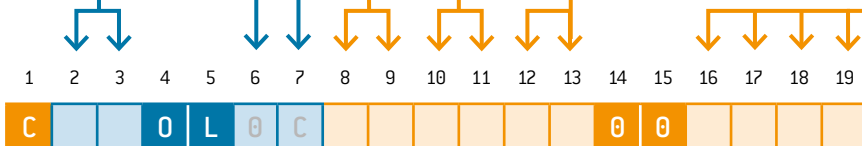

*Data rates mentioned are based on the respective standard data transmission protocol and are determined by the number of conductors of the ODU connector.

ODU MINI-SNAP® SERIES L

USB® without bend relief up to 1000 mm per single side assembly

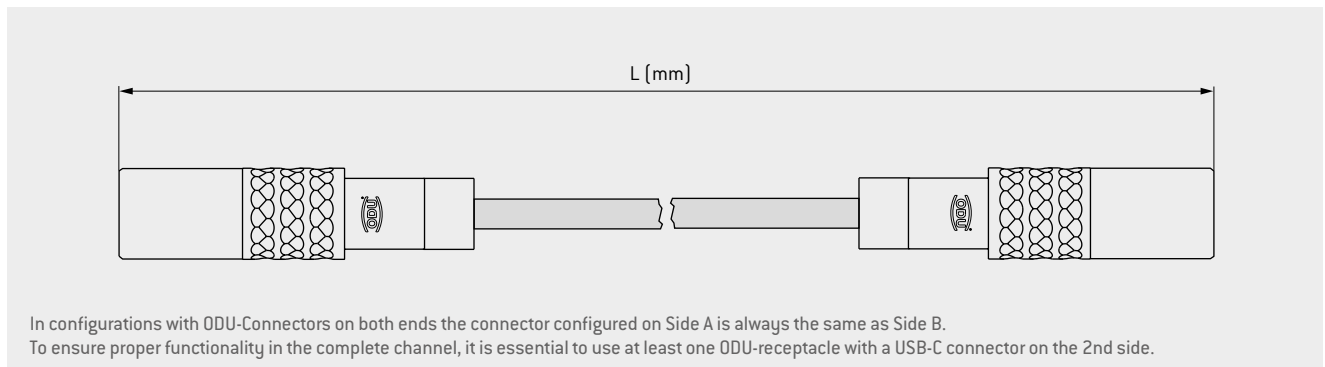
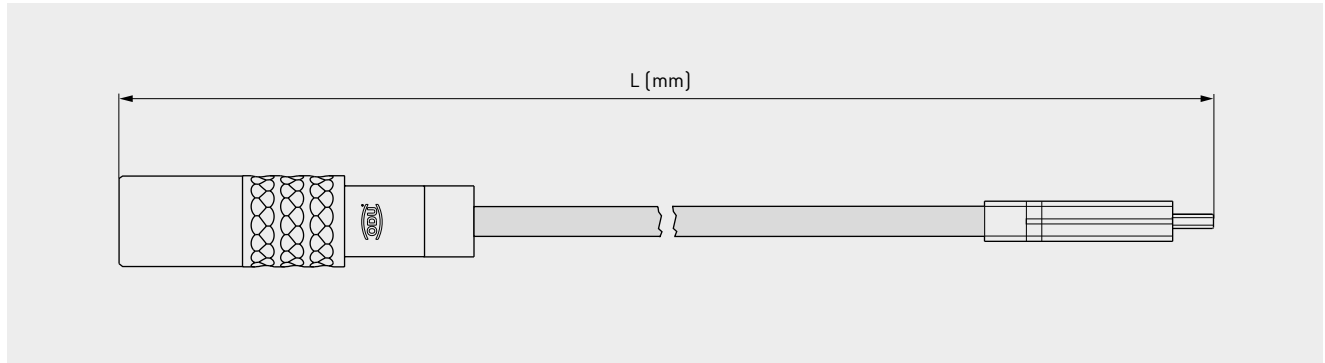

In configurations with ODU-Connectors on both ends the connector configured on Side A is always the same as Side B. To ensure proper functionality in the complete channel, it is essential to use at least one ODU-receptacle with a USB-C connector on the 2nd side.

| Pos. 2-3 | Connector type |
|----------|------------------------|
| A1 | Break-away plug |
| S1 | Push-pull plug |
| K1 | In-line receptacle |
| G6 | Panel mount receptacle |

| Data rate* | Pin/Socket | 2 nd side | Pos. 12-13 |
|------------|------------|----------------------|------------|
| 10 Gbit/s | Pin | USB® C Plug | VN |
| | | ODU-Connector | VM |
| | Socket | USB® C Plug | VL |

The available codings for the respective series can be found on page 14.

| Pos. 7 | Housing surface |
|--------|-----------------|
| C | Matte chrome |
| Z | Tin-nickel |

| Pos. 16-19 | Length |
|---|--------|
| Length L of assembly in mm (minimum cable length 300 mm) Example: 1000 mm = 1000 | |

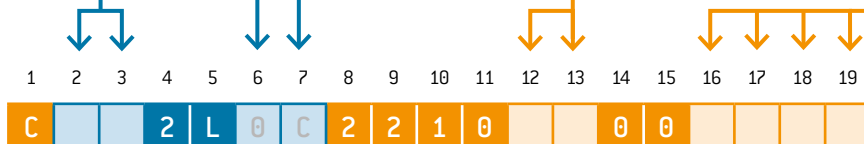

*Data rates mentioned are based on the respective standard data transmission protocol.

ODU MINI-SNAP® SERIES L

USB® with bend relief up to 1000 mm per single side assembly

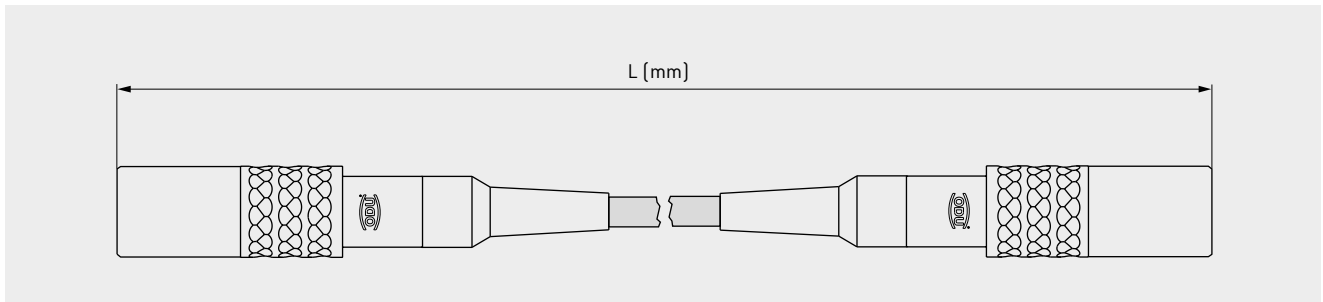
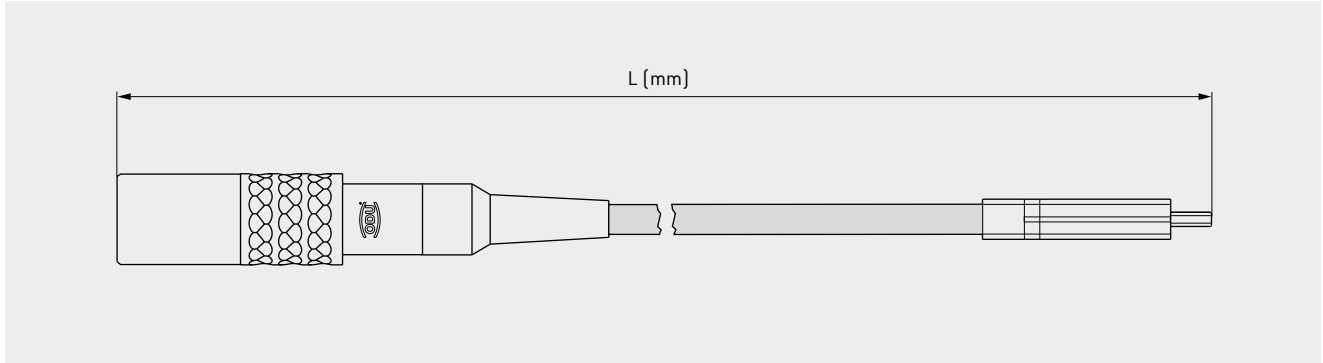

In configurations with ODU-Connectors on both ends the connector configured on Side A is always the same as Side B. To ensure proper functionality in the complete channel, it is essential to use at least one ODU-receptacle with a USB-C connector on the 2nd side.

| Pos. 2-3 | Connector type |
|----------|--------------------|
| A2 | Break-away plug |
| S2 | Push-pull plug |
| K2 | In-line receptacle |

| Data rate* | Pin/Socket | 2 nd side | Pos. 12-13 |
|------------|------------|----------------------|------------|
| 10 Gbit/s | Pin | USB® C Plug | VN |
| | | ODU-Connector | VM |
| | Socket | USB® C Plug | VL |

The available codings for the respective series can be found on page 14.

| Pos. 7 | Housing surface |
|--------|-----------------|
| C | Matte chrome |
| Z | Tin-nickel |

The available color of the bend and strain relief can be found on page 15.

| Pos. 16-19 | Length |
|---|--------|
| Length L of assembly in mm (minimum cable length 300 mm) Example: 1000 mm = 1000 | |

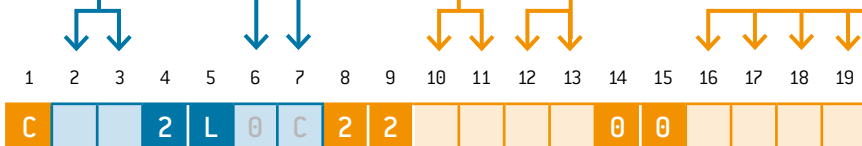

*Data rates mentioned are based on the respective standard data transmission protocol.

ODU MINI-SNAP® SERIES K

USB® without bend relief up to 3000 mm per single side assembly with transfer of 480 Mbit/s

USB® without bend relief up to 2000 mm per single side assembly with transfer of 5 Gbit/s

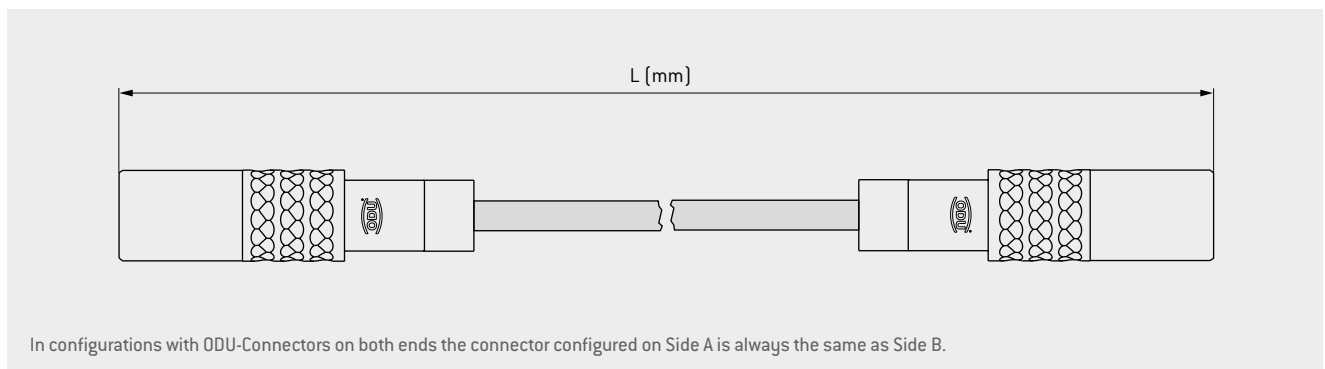
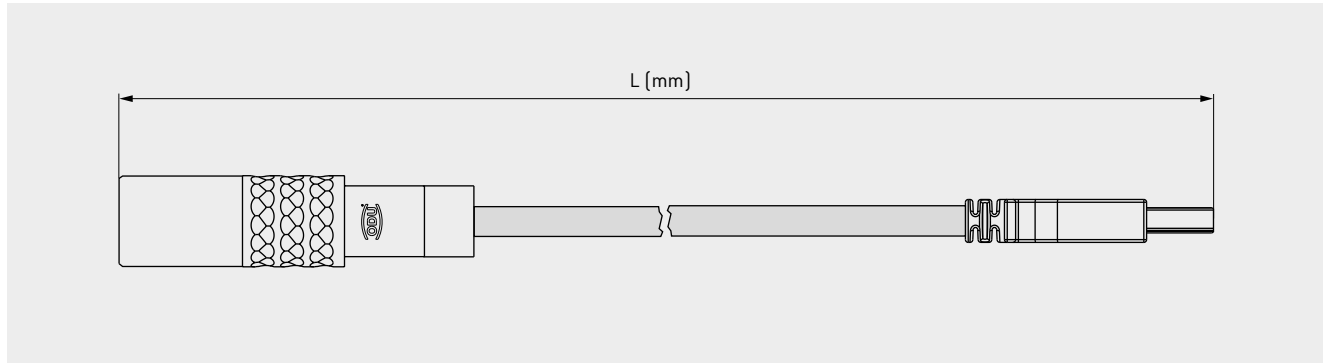

| Pos. 2-3 | Connector type |
|----------|------------------------|
| A1 | Break-away plug |
| S1 | Push-pull plug |
| K1 | In-line receptacle |
| G6 | Panel mount receptacle |

The available codings for the respective series can be found on page 14.

| Pos. 7 | Housing surface |
|--------|-----------------|
| C | Matte chrome |
| Z | Tin-nickel |

| Pos. 8-9 | Data rate* | Pin/Socket | 2 nd side | Pos. 12-13 |
|----------|------------|------------|----------------------|------------|
| 04 | 480 Mbit/s | Pin | USB® A Plug | VS |
| | | Socket | USB® A Plug | VR |
| 10 | 5 Gbit/s | Pin | USB® A Plug | VP |
| | | Socket | USB® A Plug | VQ |

| Pos. 16-19 | Length |
|---|--------|
| Length L of assembly in mm (minimum cable length 300 mm) Example: 1000 mm = 1000 | |

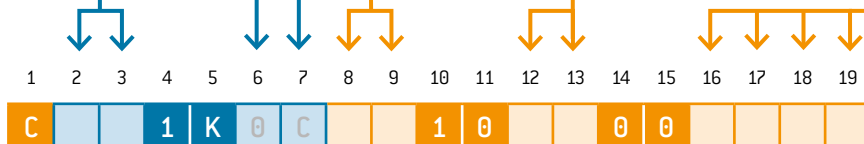

*Data rates mentioned are based on the respective standard data transmission protocol and are determined by the number of conductors of the ODU connector.

ODU MINI-SNAP® SERIES K

USB® with bend relief up to 3000 mm per single side assembly with transfer of 480 Mbit/s

USB® with bend relief up to 2000 mm per single side assembly with transfer of 5 Gbit/s

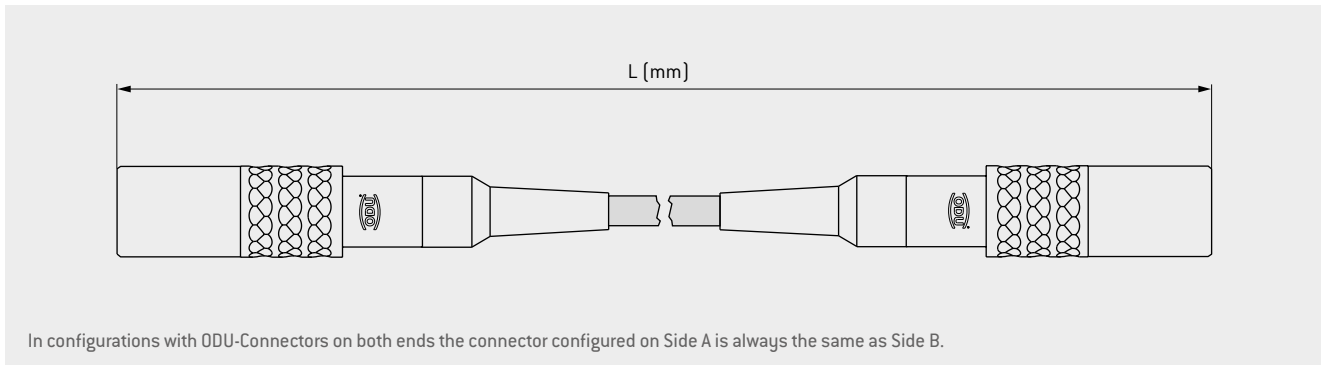
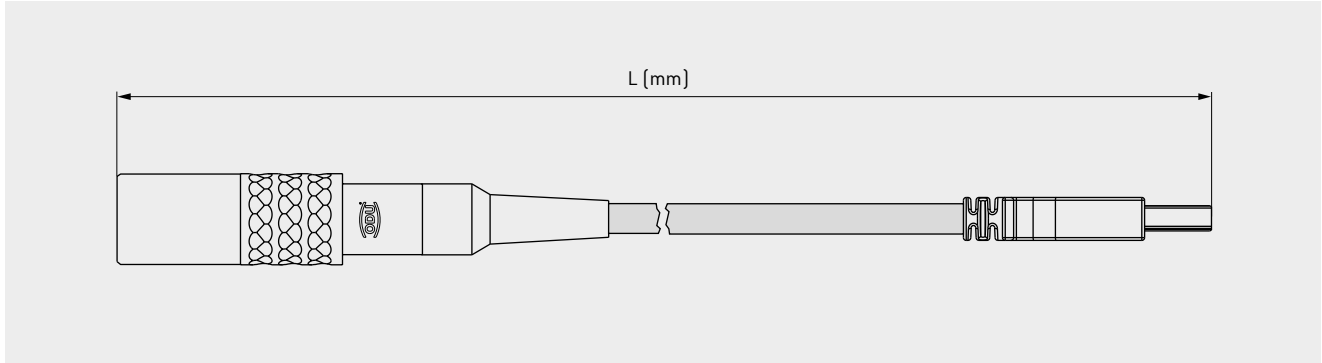

In configurations with ODU-Connectors on both ends the connector configured on Side A is always the same as Side B.

| Pos. 2-3 | Connector type |
|----------|--------------------|
| A2 | Break-away plug |
| S2 | Push-pull plug |
| K2 | In-line receptacle |

The available codings for the respective series can be found on page 14.

| Pos. 7 | Housing surface |
|--------|-----------------|
| C | Matte chrome |
| Z | Tin-nickel |

The available color of the bend and strain relief can be found on page 15.

| Pos. 8-9 | Data rate* | Pin/Socket | 2 nd side | Pos. 12-13 |
|----------|------------|------------|----------------------|------------|
| 04 | 480 Mbit/s | Pin | USB® A Plug | VS |
| | | Socket | ODU-Connector | VT |
| 10 | 5 Gbit/s | Pin | USB® A Plug | VP |
| | | | ODU-Connector | VQ |
| | | Socket | USB® A Plug | V0 |

| Pos. 16-19 | Length |
|---|--------|
| Length L of assembly in mm (minimum cable length 300 mm) Example: 1000 mm = 1000 | |

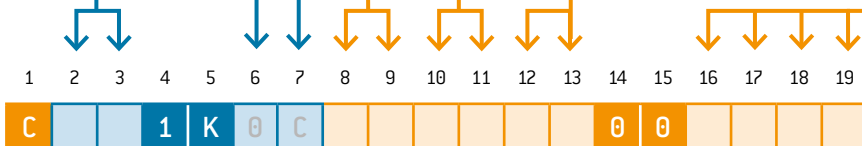

*Data rates mentioned are based on the respective standard data transmission protocol and are determined by the number of conductors of the ODU connector.

ODU MINI-SNAP® SERIES K

USB® without bend relief up to 1000 mm per single side assembly

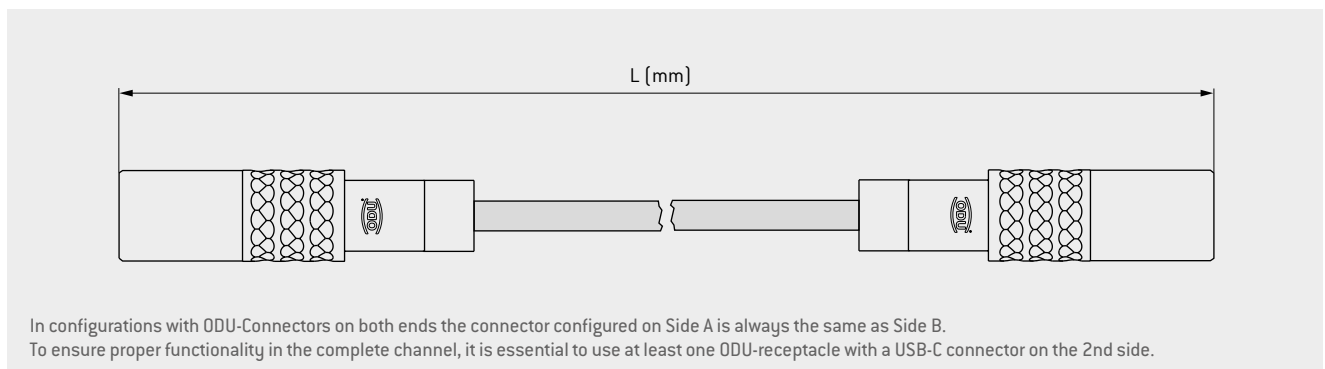
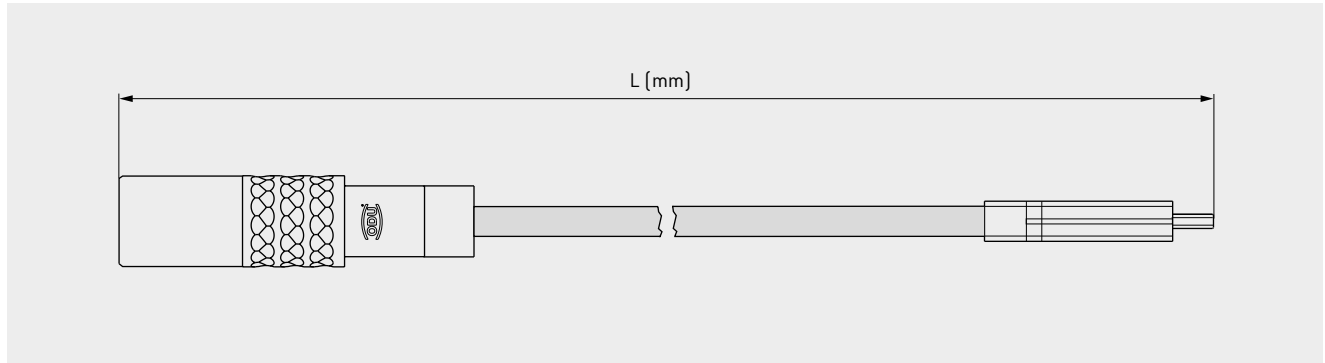

| Pos. 2-3 | Connector type |
|----------|------------------------|
| SA | Push-pull plug |
| KA | In-line receptacle |
| GB | Panel mount receptacle |

| Data rate* | Pin/Socket | 2 nd side | Pos. 12-13 |
|------------|------------|----------------------|------------|
| 10 Gbit/s | Pin | USB® C Plug | VN |
| | | ODU-Connector | VM |
| | Socket | USB® C Plug | VL |

The available codings for the respective series can be found on page 14.

| Pos. 7 | Housing surface |
|--------|-----------------|
| C | Matte chrome |
| Z | Tin-nickel |

| Pos. 16-19 | Length |
|--|--------|
| Length L of assembly in mm (minimum cable length 300 mm) Example: 1000 mm = 1000 | |



*Data rates mentioned are based on the respective standard data transmission protocol.

ODU MINI-SNAP® SERIES K

USB® without bend relief up to 1000 mm per single side assembly

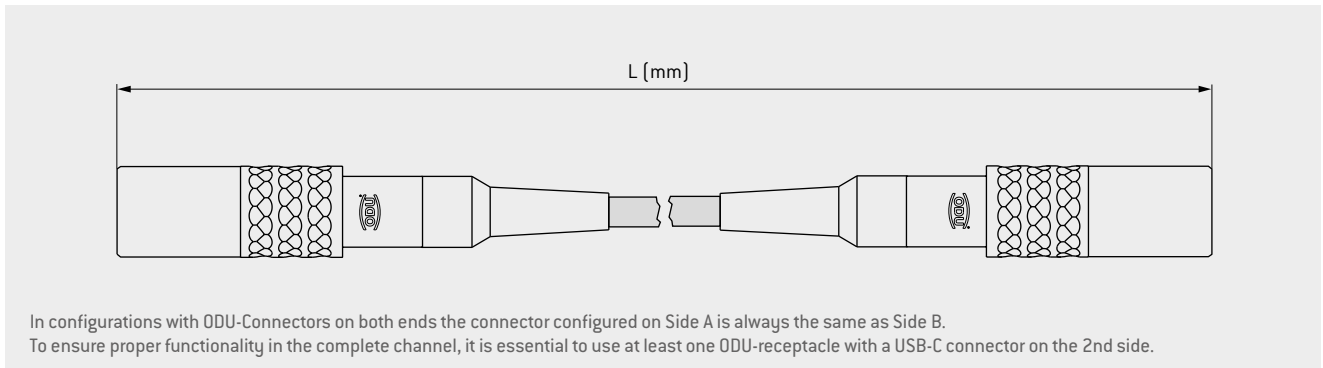
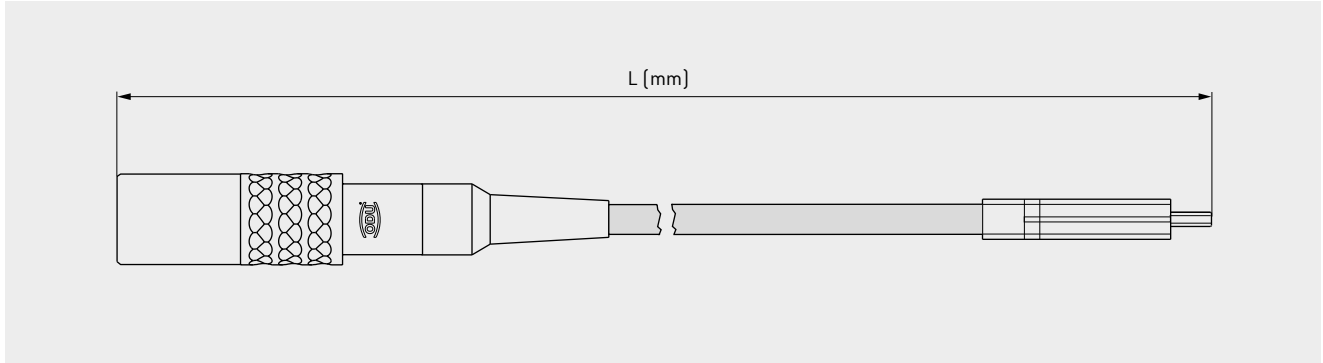

| Pos. 2-3 | Connector type |
|----------|--------------------|
| SB | Push-pull plug |
| KB | In-line receptacle |

| Data rate* | Pin/Socket | 2 nd side | Pos. 12-13 |
|------------|------------|----------------------|------------|
| 10 Gbit/s | Pin | USB® C Plug | VN |
| | | ODU-Connector | VM |
| | Socket | USB® C Plug | VL |

The available codings for the respective series can be found on page 14.

| Pos. 7 | Housing surface |
|--------|-----------------|
| C | Matte chrome |
| Z | Tin-nickel |

The available color of the bend and strain relief can be found on page 15.

| Pos. 16-19 | Length |
|---|--------|
| Length L of assembly in mm (minimum cable length 300 mm) Example: 1000 mm = 1000 | |



*Data rates mentioned are based on the respective standard data transmission protocol.

ODU-MAC® BLUE-LINE

USB® up to 3000 mm per single side assembly with transfer of 480 Mbit/s

USB® up to 2000 mm per single side assembly with transfer of 5 Gbit/s

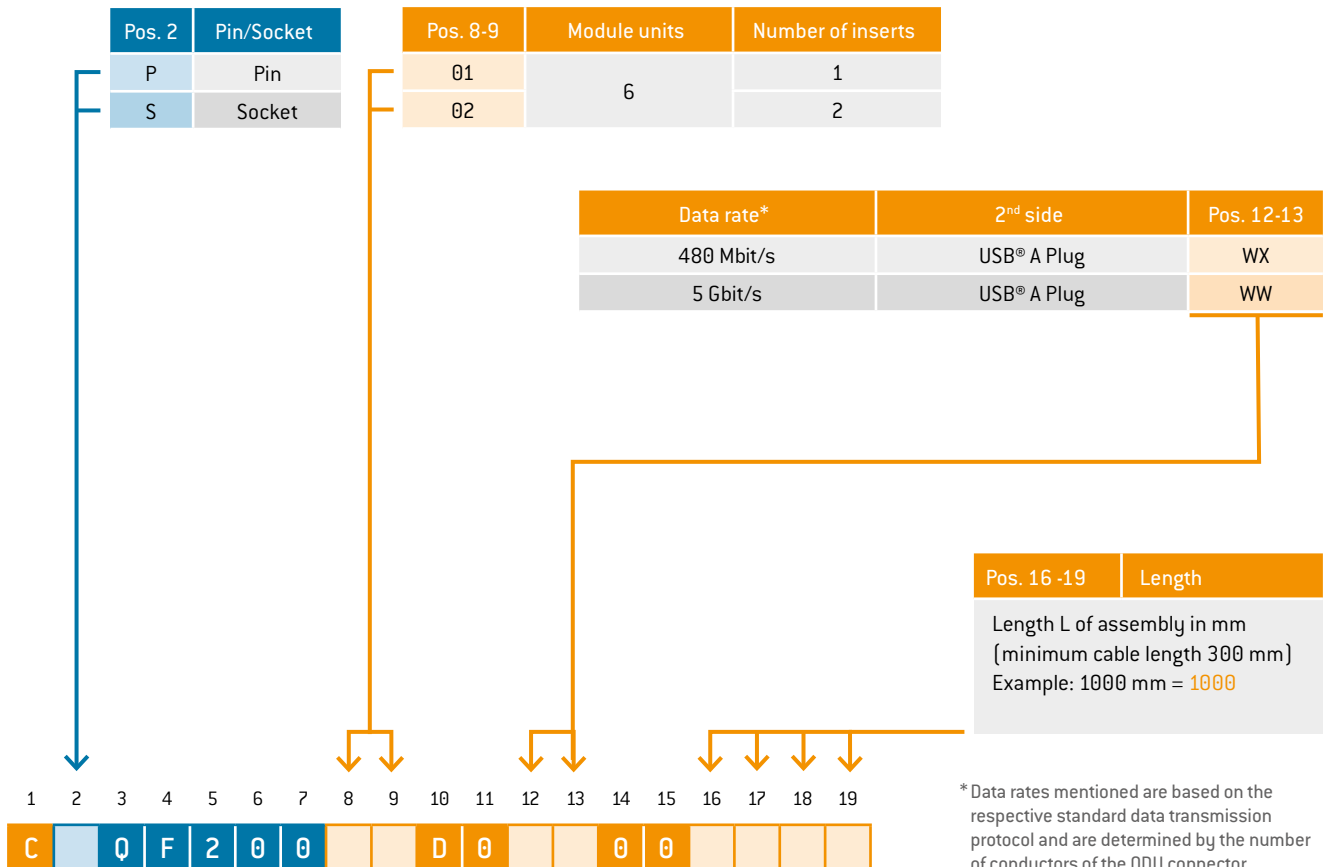
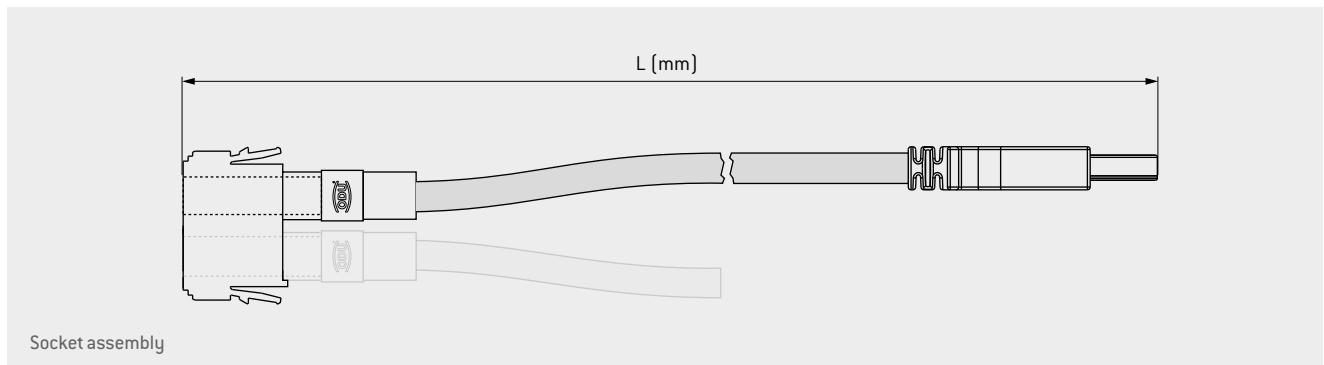
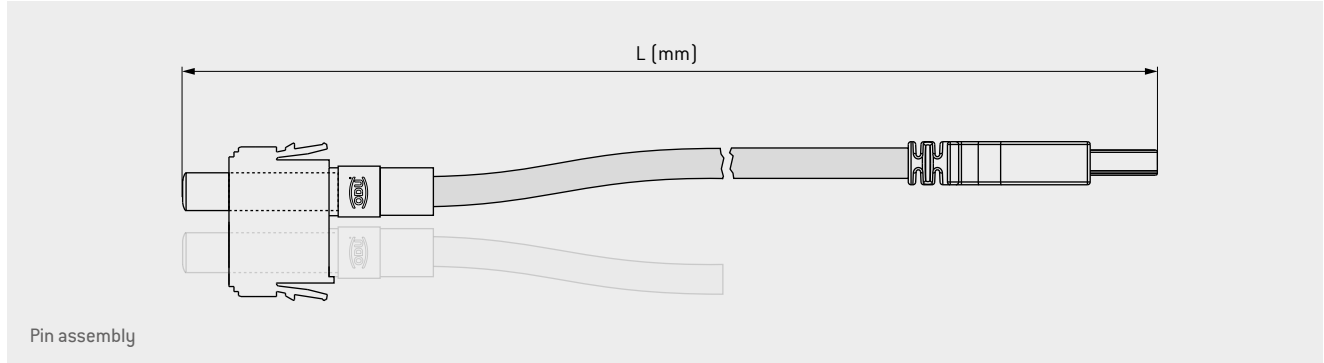

ODU-MAC® BLUE-LINE

USB® up to 1000 mm per single side assembly

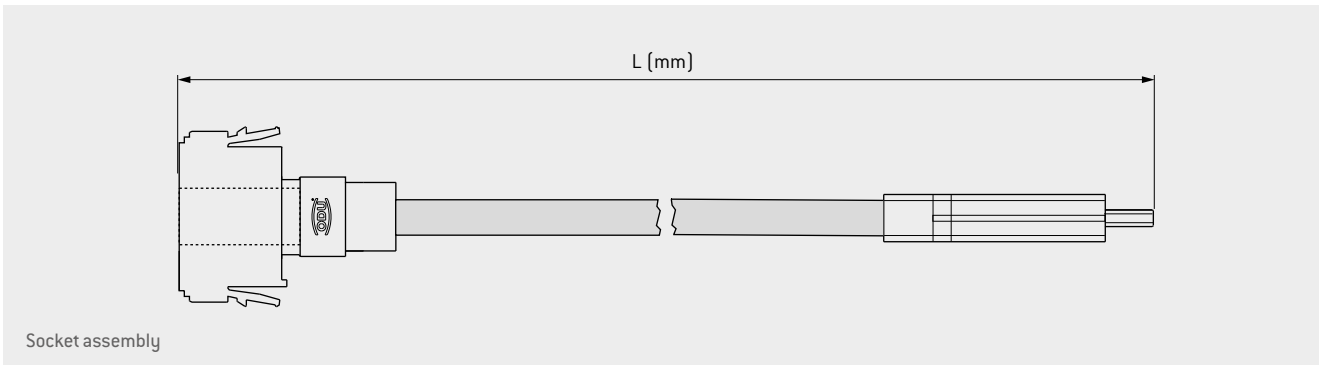
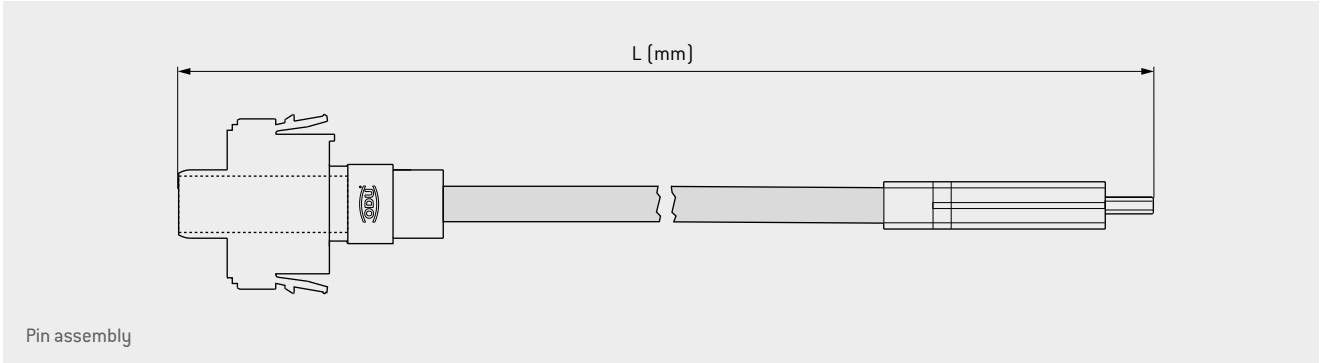

| Pos. 2 | Pin/Socket |
|--------|------------|
| P | Pin |
| S | Socket |

| Data rate* | Module units | 2 nd side | Pos. 12-13 |
|------------|--------------|----------------------|------------|
| 10 Gbit/s | 7 | USB® C Plug | WV |

| Pos. 16-19 | Length |
|--|--------|
| Length L of assembly in mm (minimum cable length 300 mm) Example: 1000 mm = 1000 | |

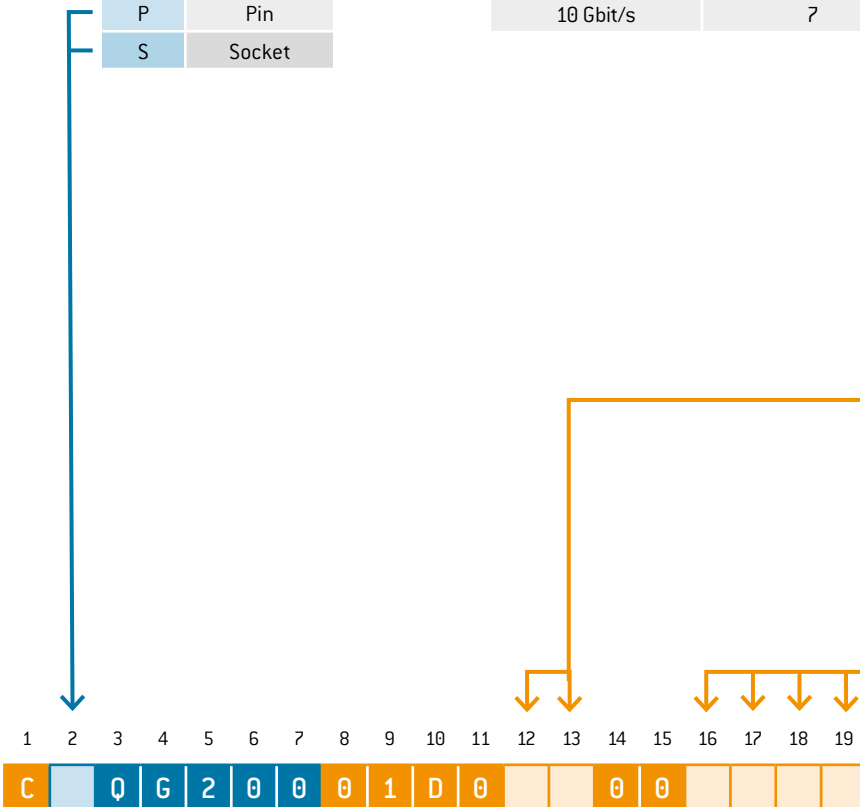

*Data rates mentioned are based on the respective standard data transmission protocol.

Алматы (7273)495-231
Ангарск (3955)60-70-56
Архангельск (8182)63-90-72
Астрахань (8512)99-46-04
Барнаул (3852)73-04-60
Белгород (4722)40-23-64
Благовещенск (4162)22-76-07
Брянск (4832)59-03-52
Владивосток (423)249-28-31
Владикавказ (8672)28-90-48
Владимир (4922)49-43-18
Волгоград (844)278-03-48
Вологда (8172)26-41-59
Воронеж (473)204-51-73
Екатеринбург (343)384-55-89

Иваново (4932)77-34-06
Ижевск (3412)26-03-58
Иркутск (395)279-98-46
Казань (843)206-01-48
Калининград (4012)72-03-81
Калуга (4842)92-23-67
Кемерово (3842)65-04-62
Киров (8332)68-02-04
Коломна (4966)23-41-49
Кострома (4942)77-07-48
Краснодар (861)203-40-90
Красноярск (391)204-63-61
Курск (4712)77-13-04
Курган (3522)50-90-47
Липецк (4742)52-20-81

Магнитогорск (3519)55-03-13
Москва (495)268-04-70
Мурманск (8152)59-64-93
Набережные Челны (8552)20-53-41
Нижний Новгород (831)429-08-12
Новокузнецк (3843)20-46-81
Ноябрьск (3496)41-32-12
Новосибирск (383)227-86-73
Омск (3812)21-46-40
Орел (4862)44-53-42
Оренбург (3532)37-68-04
Пенза (8412)22-31-16
Петрозаводск (8142)55-98-37
Псков (8112)59-10-37
Пермь (342)205-81-47

Ростов-на-Дону (863)308-18-15
Рязань (4912)46-61-64
Самара (846)206-03-16
Санкт-Петербург (812)309-46-40
Саратов (845)249-38-78
Севастополь (8692)22-31-93
Саранск (8342)22-96-24
Симферополь (3652)67-13-56
Смоленск (4812)29-41-54
Сочи (862)225-72-31
Ставрополь (8652)20-65-13
Сургут (3462)77-98-35
Сыктывкар (8212)25-95-17
Тамбов (4752)50-40-97
Тверь (4822)63-31-35

Тольятти (8482)63-91-07
Томск (3822)98-41-53
Тула (4872)33-79-87
Тюмень (3452)66-21-18
Ульяновск (8422)24-23-59
Улан-Удэ (3012)59-97-51
Уфа (347)229-48-12
Хабаровск (4212)92-98-04
Чебоксары (8352)28-53-07
Челябинск (351)202-03-61
Череповец (8202)49-02-64
Чита (3022)38-34-83
Якутск (4112)23-90-97
Ярославль (4852)69-52-93

Россия +7(495)268-04-70

Казахстан +7(7172)727-132

Киргизия +996(312)96-26-47

<https://odu.nt-rt.ru> || oud@nt-rt.ru